



Glass products offered by
Pilkington IGP Sp. z o.o.

Table of contents

1. About NSG GROUP	7
2. About Pilkington IGP Sp. z o.o.	9
3. Product catalogue	11
3.1 Solar control	11
3.2 Thermal insulation	11
3.3 Fire protection	13
3.4 Noise control	13
3.5 Safety/security	13
3.6 Self-cleaning	14
3.7 Decoration	14
3.8 Health applications	14
3.9 Special applications	15
4. Formal basics of glass processing and production of insulating glass units	16
5. Product marking	17
6. Glass processing	20
6.1 Edge treatment of the glass edge	20
6.2 Cutting out shapes	21
6.3 Drilling holes	22
6.4 Locations and limitations of cuts	23
7. Lamination	23
7.1 Bulletproof glass	24
7.2 Laminated glass for glass floors and stairs	25
7.3 Toughened safety glass and heat-strengthened glass	26
7.4 Toughened glass heat soak test	27
8. Screen printed glass and enamelled glass	28
8.1 Guideline to assess the visible quality of enamelled or screen printed glass, produced by Pilkington IGP	29
8.2 Testing	30
8.3 Allowable discrepancies for the visible quality of enamelled or screen printed glass products	30
8.4 Assessing the colour impression	31
8.5 General comments	31
9. Tolerances and acceptable defects for toughened, heat soaked toughened, heat strengthened glasses and for laminated glass – according to relevant European standards	32
9.1 Glass sheets without edge processing	32
9.2 Toughened, heat soaked toughened, heat strengthened glass	33
9.3 Laminated glass	34
10. Insulating glass units	36
10.1 Insulating glass unit with integrated blinds	38
10.2 Spacers types	41
10.3 Muntins	41
10.4 Guidelines for the use of Georgian bars in Insulating Glass Units	43
10.5 Gases	43
10.6 Sealing compounds	44

10.7	Using construction sealant for sealing insulating glass units	44
10.8	Insulating glass units intended for use in mountain areas	47
10.9	Toughened and heat strengthened glass	48
10.10	Glass deflection due to changes in temperature and atmospheric pressure	48
10.11	Thermal cracks	49
10.12	Mechanical cracks	49
10.13	Standard size limits of IGUs, delivered by Pilkington IGP	51
11.	Permissible tolerances of dimensions and thickness of insulating glass units	52
12.	Fire protection glass	52
12.1	Offered products	53
12.2	Fire-resistant glass codes	53
12.3	Guidelines for transport, assembly and storage of fire-resistant glass units	54
12.4	Pilkington Pyrostop [®] or Pilkington Pyrodur [®] glass units installation	55
13.	Washing and cleaning of glass supplied by Pilkington IGP	55
13.1	Washing and handling of self-cleaning glass	56
13.2	Washing glass at the construction site	57
14.	Construction site proceedings	57
15.	Packing of glass	58
15.1	Packing – metal racks	58
15.2	Packing – wooden packages	60
15.3	Positioning and securing glass on the racks	61
15.4	Unloading	62
15.5	Shipping documents and receipt of goods	62
16.	Annex 1: Standard warranty general conditions for insulating glass units	63
17.	Annex 2: Pilkington IGP processed glass manufacturing standards	64
18.	Annex 3: Criteria for quality assessment of glass products	68
19.	Annex 4: Information for the users of Insulating Glass Units (IGUs) manufactured by Pilkington IGP Sp. z o.o.....	72
20.	Annex 5: Instructions of storage, transport, installation, use and maintenance of glass products	73
21.	Annex 6: Quality assessment criteria for ScreenLine[®] integrated blinds	76
22.	Annex 7: Information on the occurrence of water vapour condensation on the outer surfaces of the glass ...	81
23.	Annex 8: Information on glass disinfection	81
24.	Annex 9: Information on the service of glass wrapping	82
25.	Annex 10: Information for customers ordering glass products made of customer-provided glass	82
26.	Annex 11: Triple glazed insulating units – information on specific product features and issues requiring attention when choosing glazing design	84
27.	List of contacts	86

List of figures

Fig. 1. Pilkington IGP in Poland	9
Fig. 2. Declaration Of Performance example	16
Fig. 3. Examples of permanent marking of toughened glass sheets, heat strengthened glass sheets and toughened and heat soaked glass sheets.	17
Fig. 4. An example of marking on a laminated glass of P4A Class.	17
Fig. 5. An example of a special marking on toughened glass	17
Fig. 6. An example of an imprint on the frame of the insulating glass unit spacer	18
Fig. 7. Example of the main and side stickers with explanations of the information provided	19
Fig. 8. Cross-section of the hole	22
Fig. 9. Locations and limitations of cuts	23
Fig. 10. View of the toughened glass fracture pattern in which a spontaneous breakage could occur due to NiS inclusion	27
Fig. 11. Construction of the insulating glass unit	36
Fig. 12. Low-emissivity double glazed insulating glass unit	37
Fig. 13. Low-emissivity triple glazed insulating glass unit	37
Fig. 14. Rubber plug in the spacer hole	47
Fig. 15. Standard thermal crack	49
Fig. 16. Striking the glass surface, e.g. by throwing a stone	49
Fig. 17. Striking the corner	49
Fig. 18. Striking the edge (placing on a stone or piece of metal)	49
Fig. 19. Striking the edge (hitting the glass surface, e.g. hitting the pane strip with a hammer	50
Fig. 20. Pressure on the edge (e.g. incorrect blocks for the glass weight)	50
Fig. 21. Crack caused by surface pressure	50
Fig. 22. Sticker on fire-resistant glass units	54
Fig. 23. L-type metal rack, stacked	58
Fig. 24. MEGA/GIGA type metal rack	58
Fig. 25. L-type metal rack, stacked	59
Fig. 26. Type A metal rack	59
Fig. 27. L-type wooden rack	60
Fig. 28. Wooden crate	60
Fig. 29. Marking of wooden racks	60
Fig. 30. Example methods of packing and securing glass on racks.	61
Fig. 31. Example methods of packing and securing glass on racks	62
Fig. 32. Lower rail parallelism	76
Fig. 33. Central deflection of the lower rail	76
Fig. 34. Tilt angle of the slats	78
Fig. 35. Parallelism of the slats	78
Fig. 36. Observation of defects	79

List of tables

Table 1. Types of processing	20
Table 2. Curved shapes machining	21
Table 3. Guidelines for the holes' locations	22
Table 4. Guidelines for the number of film interlayers	23
Table 5. Dimensions for laminated toughened glass.	23
Table 6. Classification of laminated glass according to EN 12600.	24
Table 7. Classification of laminated glass according to EN 356.	24
Table 8. Dimensions of toughened glass.	26
Table 9. Dimensions of thermally toughened glazing	26
Table 10. EN 12600 glass classification	26
Table 11. Dimensions for glass subjected to HST.	27
Table 12. Dimensions – enamelling	29
Table 13. Dimensions – screen printing	29
Table 14. The requirements to visual quality of glass products.	30
Table 15. Dimensional (width/height)	32
Table 16. Edge defects – glass sheets without edge processing	32
Table 17. Overall bow, roller wave, edge lift	33
Table 18. Spot and linear defects	33
Table 19. Tolerances on hole diameters	33
Table 20. Limitations for position of holes	33
Table 21. Limit deviations on width L and length H	34
Table 22. Maximum displacement	34
Table 23. Permissible spot defects in the vision area - spot defects	35
Table 24. Number of permissible defects in the vision area – linear defects	35
Table 25. Installation of internal and external muntins	42
Table 26. Gases used	43
Table 27. Standard dimensional limits for insulating glass units	51
Table 28. Permissible tolerances of dimensions and thickness of insulating glass units	52
Table 29. Products offered by Pilkington IGP	53
Table 30. Acceptable defects visible from a distance of 2 m	69
Table 31. Permissible tolerances of dimensions and thickness of insulating glass units	69
Table 32. List of silicones and mounting adhesives compatible with standard Insulating Glass Units manufactured by Pilkington IGP Sp. z o.o. (sealed with polyurethane compounds)	72
Table 33. List of silicones and mounting adhesives compatible with standard Insulating Glass Units manufactured by Pilkington IGP Sp. z o.o. sealed with structural silicones	72
Table 34. Level of dirt on the tips of the slats (t)	80
Table 35. Slats' colour and the colour difference Slat colour/Dirt colour, difference	80
Table 36. Acceptable discolouration for the slats	80

1. About NSG GROUP

The NSG Group is currently one of the world's largest manufacturer of glass and glass products, operating in three main sectors: Automotive, Architectural and Creative technology.

Our Businesses:



1. Architectural glass business unit

Architectural manufactures and supplies architectural glass as well as glass for the solar energy and other sectors.



2. Automotive glass business unit

Automotive serves the original equipment (OE) and aftermarket replacement (AGR) glazing markets.

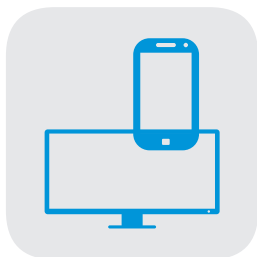

3. Creative technology business unit

Creative Technology comprises several discrete businesses, including lenses and light guides for printers and scanners, and specialty glass fiber products such as glass cord for timing belts and glass flake.

MISSION

Changing our surroundings,
improving our world.

ASPIRATION

Through innovation, becoming the most
trusted partner in all industries we work in.

CORE VALUES

- Respect others and unleash their potential
- Respect others and unleash
- Ensure efforts to serve society
- Take the initiative
- Embrace challenges and learn from failure
- Follow through to get results

2. About Pilkington IGP Sp. z o.o.

MANUFACTURER OF PROCESSED GLASS AND A LEADER IN THE MARKET OF INSULATING GLASS UNITS

The history of the company dates back to 1991, when the IGP S. A. company was established in Skierniewice, where the production of insulating glass began two years later. In 1993, a sales office was opened in Warsaw. Along with the growing demand for glass, further plants started production.

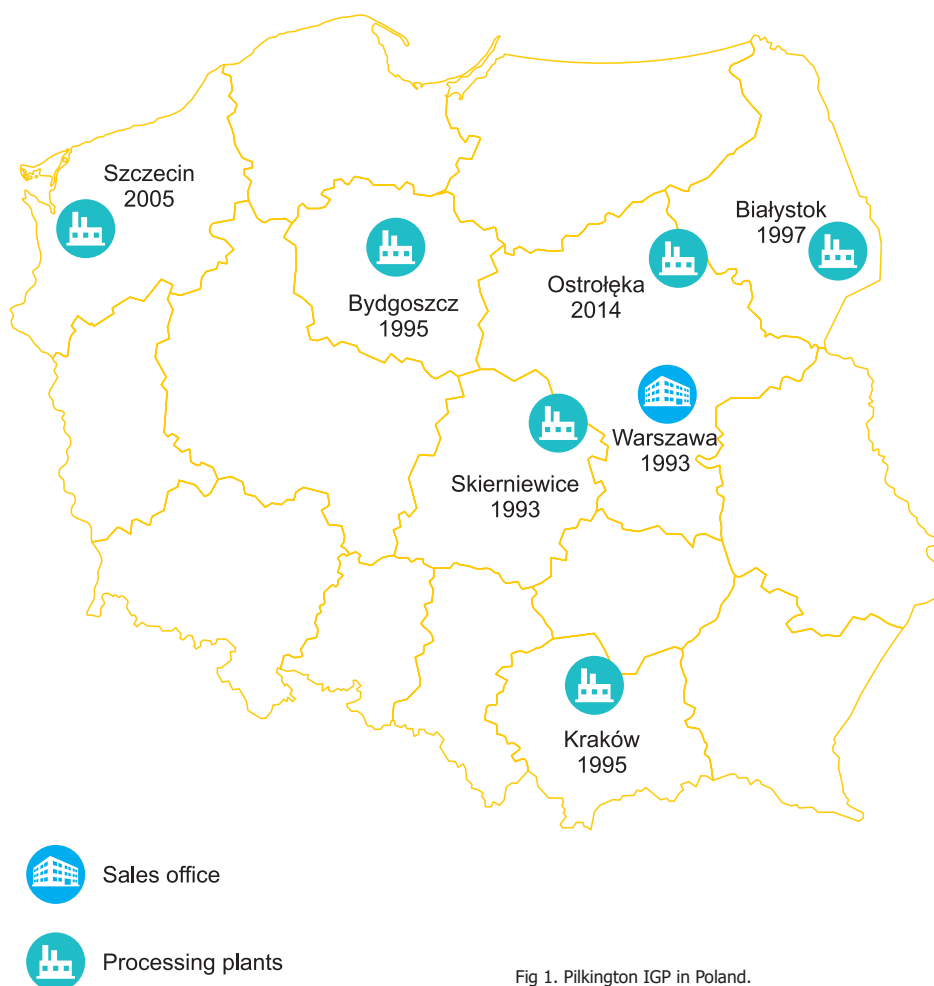

Fig 1. Pilkington IGP in Poland.

After nearly thirty years of activity and continuous investment and development, Pilkington IGP currently employs around 1,400 people and is one of the leading glass processors and insulating glass manufacturers in Europe with an annual production of more than 4 million insulating glass units. Currently, the Company consists of six branches, which are constantly modernised in order to gradually increase production capacity, while improving the operational efficiency and ergonomics. Pilkington IGP is building its competitive advantage by continuously expanding its product range, confirmed by numerous certificates.

What distinguishes the company is the constant care for development and technical support that our customers can count on. In 1999, the ISO 9001 quality management system was introduced in all of our plants, and in 2001, the ISO 14001 environmental management system was also introduced. These certificates confirm the constant care for the good quality of products and the process execution in accordance with environmental standards while maintaining work safety.

Pilkington IGP specialises in the production of insulating glass and glass processing. The company offers insulating glass with a wide range of highly processed products for the construction sector, such as solar control glass, low-emissivity glass, self-cleaning glass, sound insulating glass, etc. In addition to the production of insulating glass, Pilkington IGP manufactures toughened, laminated (including bulletproof and soundproof), fireproof, enamelled and screen printed glass.

The main business partners of Pilkington IGP are manufacturers of windows and building façade contractors, both domestic and foreign. The company's wide product range obviously translates into the market attractiveness of the windows manufacturers' offer. Thanks to the advanced technologies introduced by the company, business partners have a very wide and varied package of innovative glass products at their disposal, which increases the attractiveness of the final product (windows and façades) from the perspective of the end customer. The wide range of Pilkington IGP insulating glass units allows windows manufacturers and façade contractors to freely shape the performance of windows and to create glazed façades perfectly suited to individual needs. The rich portfolio of clients also includes the largest companies operating in the field of internal glazing.

Thanks to state-of-the-art production lines, we can provide products of the highest quality of the required characteristics.

Pilkington IGP is also a leading supplier of glass for architectural projects. Among the large-format projects where the glass signed with the Pilkington IGP quality mark was used, there are such impressive projects as acoustic half-tunnels over the AK route in Warsaw, Warsaw Metropolitan office buildings, Aeropark Business Centre, Harmony Office Center, Platinum Business Park and the Lotos headquarters in Gdańsk, etc.

It is the quality that comprises many years of experience, flexibility in approaching expectations, efficiency in the implementation of the sales process and expertise that makes Pilkington IGP a responsible business partner. What is important here is cooperation with design offices, assistance in the selection of glass at the building design stage, preparation of offers, and once the contract is signed, appropriate organisation and supervision of deliveries.

In terms of experience and the current technological possibilities, Pilkington IGP is a recognised leader in the industry, which is reflected both in the composition of the group of clients and the projects supported in Poland, the Czech Republic, Ukraine, Sweden, Lithuania, Norway and other European countries.

3. Product catalogue

3.1 Solar control

Pilkington **Suncool™** is a clear float glass covered with a thin layer of coating that transmits a large amount of light while reducing the transmittance of solar radiation. The low-emissivity properties of the coating mean that the heat that tries to escape from the room is reflected back into it. The hallmark of Pilkington **Suncool™** high performance solar control glass is the fact that its light transmittance is clearly higher than its total solar energy transmittance. Like any off-line coated low-emissivity glass (manufactured off the float glass production line), Pilkington **Suncool™** can only be used in insulating glass units. Pilkington **Suncool™** glass is available in annealed, toughened and laminated versions. Pilkington **Suncool™** is a range of solar control glass with high light transmittance, low solar energy transmittance and excellent thermal insulation.

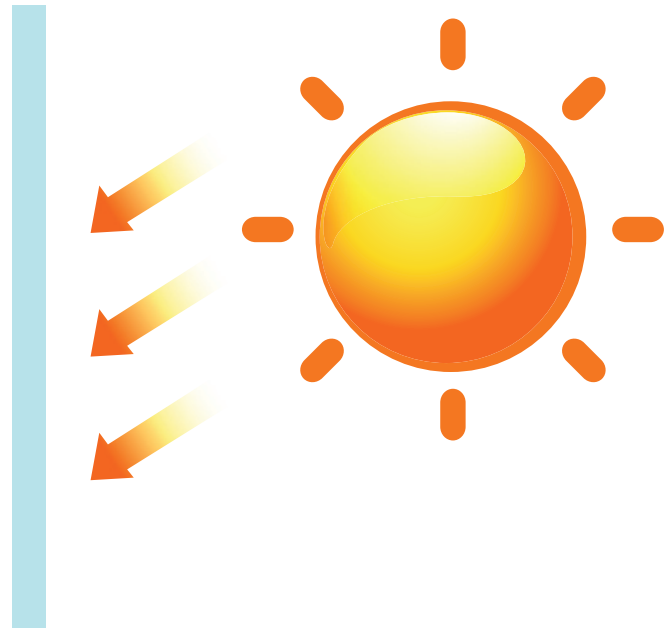

3.2 Thermal insulation

Most of our products are made using the float glass process. The process was developed by Sir Alastair Pilkington in 1952. Today, it is the standard method used globally for the production of high-quality glass. The process, which initially made it possible to produce glass with a thickness of 6 mm, is now used to produce glass with a thickness of 0.4–25 mm. A batch of mixed raw materials is melted in a furnace. Liquid glass with a temperature of around 1000°C is continuously poured from the furnace into a shallow tank filled with liquid tin in a controlled atmosphere. The glass spreads across the surface of the tin, creating a perfectly flat surface. The thickness of the glass is controlled by the speed at which the solidifying glass ribbon flows out of the tin bath. After annealing (controlled cooling), a ribbon of glass with perfectly parallel surfaces is formed, technically free from defects that cause distortions of the image seen through the glass.

Pilkington **Optifloat™** Clear is the brand name for high quality float glass. The transparent glass with a uniform thickness is completely free from optical distortions, so it is perfect for applications where an undisturbed view is required.

Insulating glass units manufactured by Pilkington IGP have the brand name Pilkington **Insulight™** which is a state-of-the-art and technically advanced product. The units are equipped with a dual seal system between the spacer and two or three panes of glass, which increases the service life of the product. Insulating glass units are manufactured on automated, specialised production lines, using the highest quality components. Quality is controlled at every stage of production, which ensures the high quality of the final product. Insulating glass units can include any glass configuration from the wide range of Pilkington glass to provide: fire resistance, safety and security, thermal insulation, solar control, noise control and decoration.

Pilkington **Insulight™** Therm are double or triple insulating glass units made of Pilkington **Optifloat™** Clear glass and Pilkington **Optitherm™** S3 low-emissivity glass, Pilkington **Optitherm™** S1A glass or Pilkington **Optitherm™** S3 Pro T glass. Insulating glass units made of these glass types offer increased thermal insulation properties, and ensure increased comfort of use and reduced condensation. They are used wherever it is required to reduce energy consumption and heat loss, both in apartments and single-family houses, as well as in curtain walls and façades of commercial and public buildings. Pilkington **Optitherm™** S3 is a neutral low-emissivity glass characterised by high light transmittance and low reflectivity, but also a low heat transfer coefficient $U_g = 1.1 \text{ W/m}^2\text{K}$.

For applications requiring a heat transfer coefficient at the level of $1.0 \text{ W/m}^2\text{K}$ Pilkington **Optitherm™** S1A glass can be used. This product provides both excellent light transmittance and colour neutrality. The heat transfer coefficient U is a measure of thermal insulation. The lower the U heat transfer coefficient is, the better the thermal insulation.

Triple insulating glass units Pilkington **Insulight™** Therm Triple with the latest low-emissivity glass Pilkington **Optitherm™** S1A obtain a heat transfer coefficient U_g at the level of $0.4 \text{ W/m}^2\text{K}$ (according to EN 673).

Benefits

- Reduction of heat loss, and thus reduction of internal space heating costs.
- Reduction of cold places and the phenomenon of "cold draught" from the window, improving the comfort in rooms and increasing the usable floor area.
- Higher temperature of the inner pane, and therefore lower risk of condensation.
- Reduction of water vapour condensation at the edges of insulating glass units with the use of "warm" spacers.
- High light transmittance.
- Larger window area in buildings, thanks to the lower U -value compared to traditional glazing.
- Can be combined with various types of glass to provide decorative features, solar control, safety, etc.
- Can be installed in apartments, single-family houses, winter gardens, façades and curtain walls.

3.3 Fire protection

Today's buildings, in accordance with applicable regulations, should ensure an appropriate level of fire safety. Float glass, commonly used in the construction industry, is completely non-resistant to fire. It breaks at a temperature difference of ΔT 40°C within one glass sheet. So-called safety glass also do not constitute any barrier against fire. Laminated glass breaks as quickly as float glass, and breaks up into pieces at a temperature of approx. 250°C, once the PVB film, after melting, no longer holds the glass pieces together. Toughened glass is more resistant to high temperatures, but not higher than 300–350°C. In order to protect people during a fire and to ensure the possibility of using the escape routes in buildings, it is necessary to use glass resistant to a temperature of 1000°C.

Products that can stand such high temperatures are Pilkington **Pyroduer**® and Pilkington **Pyrostop**®. These products have a completely transparent gel located between the subsequent glass layers. The gel foams under the influence of strong thermal radiation, forming a stable, non-transparent layer that separates the room from the fire. These glass products have also been tested for impact resistance according to EN 12600 and have the highest safety class for laminated glass 1(B)1.

Another type of glass offered is Pilkington **Pyroclear**® monolithic fire-resistant glass for applications where Class E protection is required. This type of glass also has the highest safety class for toughened glass 1(C)1.

All offered fire-protection glass types provides an increased level of protection, measured in a defined time interval (30, 60, 90, 120 and 180 minutes) in terms of fire insulation and integrity or only fire integrity in accordance with European standards. It should be noted that fire-resistant glass must always be specified as part of an approved fire-resistant system and all fire-resistant components must be installed by a specialist who can ensure that the expected fire resistance is achieved.

3.4 Noise control

Noise control glass is a product that has been increasingly used in recent years. The range of noise control glass with increased noise reduction parameters meets the growing demand for noise control. Pilkington **Optiphon**™ glass is a high quality acoustic laminated safety glass that combines high performance of sound insulation with safety requirements. The characteristics of Pilkington **Optiphon**™ glass makes it possible to achieve a high R_w sound insulation index without the use of resins. Moreover, due to its technical properties, the glass meets the safety standards for Class P2A, given in EN 356.

3.5 Safety/security

Toughened glass is manufactured in the process of toughening – glass sheets cut to size are heated and rapidly cooled. During this process, compressive stresses are created on the surface of the glass pane, and tensile stresses in the interior that balance the surface compressive stress. It is the compressive stress that makes the toughened glass even 2.5 times stronger than panes made of annealed glass of the same thickness. The increased mechanical strength of toughened glass enables architects and construction companies to expand the scope of applications in construction. Pilkington Toughened Glass meets international standards for safety glass, which is confirmed by the appropriate certificates. Toughened glass is a safety glass – if broken, it breaks into small, blunt pieces. Once the toughening process is complete, the glass can no longer be subjected to any mechanical treatment, as this would disturb the stresses inside the glass and lead to immediate breakage. All types of processing such as trimming to the appropriate size, cutting out shapes, edge processing and drilling holes should be performed before the toughening process.

Laminated glass is produced by bonding two or more glass panes with one or more organic interlayers. The most commonly used interlayer is PVB (Poly Vinyl Butyral) film, which is glued to the glass under high pressure and temperature. Pilkington **Optilam**™ is the brand name for laminated safety glass that breaks when subjected to impact, but the pieces of the broken glass remain stuck, thereby protecting people from serious injury. The technical parameters of Pilkington **Optilam**™ laminated safety glass may differ depending on the amount, thickness and type of the individual glass sheets used, as well as the interlayers. As a result, the product can be tailored to specific functions, such as: safety, security, noise control, bullet resistance, detonation resistance, solar control, UV protection or decoration. It provides a wide selection of glass tailored to a specific application.



3.6 Self-cleaning

Thanks to the development of Pilkington **Activ™**, the world's first dual-action self-cleaning glass, the NSG Group has taken a significant step in the evolution of glass technology. A special self-cleaning coating, activated by daylight, breaks down organic dirt and rainwater flushes all of the loosen dirt from the glass surface. Thanks to this effect, investors erecting private and commercial buildings around the world can benefit from the economic and aesthetic advantages of clean windows, roof glazing and winter gardens. Pilkington **Activ™** dries faster and the windows remain streak-free for a clear and pristine view.

In addition to cleanliness, gloss and transparency, glazing in public buildings and office buildings also play other roles. With the self-cleaning function, Pilkington **Activ™** products can combine compliance with the requirements in the field of solar control, thermal insulation and noise control, as well as stricter safety

regulations. Availability of dual coated products and laminating possibilities allow the manufacture of the glass products that ensure aesthetics, safety, comfort and cost-effective operation of modern buildings, allowing best cost-effective management of buildings.

Solar control products from the Pilkington **Activ™** family provide a wide range of solar control solutions, including for places that are difficult to access for cleaning, such as roof and sloped glazing, which are also often the most exposed surfaces to dirt and solar radiation.

3.7 Decoration

The use of glass for decoration has many unique benefits. There are several different solutions to print a pattern, change the colour or to impart a distinctive character to the glass surface, determining the degree of transparency or clarity of the glass. The range of glass types for decorative purposes includes transparent or translucent products such as screen printed glass, laminated glass with translucent interlayer, sandblasted glass and patterned glass. Decorative products also include non-transparent products such as enamelled glass and spandrel glass used to clad the area between the windows.

Pilkington Texture Glass is a rolled patterned glass, one surface of which has a specific pattern or design impressed into the surface, which creates decoration. The effect of partial masking or darkening obtained with the use of this type of glazing can be achieved by discolouring the glass mass to a brown colour or by selecting a more or less discreet pattern.

The light falling on the patterned glass is partially diffused and reflected, depending on the pattern selected. Thanks to this, interesting visual effects are obtained, limiting the transparency of the glass and creating a sense of intimacy in the selected areas of the building interior.

The total transmittance of patterned rolled glass is not much lower than that of standard glass, so the overall level of illumination in rooms remains at a comparable level.

3.8 Health applications

Pilkington **SaniTise™** is an online coated glass with a transparent photocatalytic coating that provides antimicrobial properties and activity against enveloped viruses when exposed to UV.

The coating on glass retains its properties even when UV exposure ends, for up to 2 hours in tests, further reducing the risk of cross-infection.

3.9 Special applications

Pilkington Anti-condensation Glass significantly reduces the risk of condensation on the outer surface of insulating glass units, at the same time providing a high level of thermal insulation.

Pilkington **AviSafe™** is an innovative glass solution, developed to greatly reduce the number of bird collisions. The unique patterned UV enhanced coating disrupts the reflection on the glass, so the bird can see a barrier.

Pilkington **Mirropane™** Chrome is a highly reflective coated glass designed for use in mirrors. It is not only an element of interior decoration, but due to the possibility of toughening and lamination, it can also be used in places with increased safety requirements. Thanks to its moisture-resistant coating, Pilkington **Mirropane™** Chrome glass combines functionality with aesthetics, allowing for extensive design possibilities. An interesting type of chrome mirror is Pilkington **Mirropane™** Chrome Spy, often referred to as "spy glass" and used for undetected surveillance applications.

Pilkington **OptiShower™** is a float glass coated with a durable on-line coating that prevents surface corrosion that may occur during prolonged exposure to moisture.

Pilkington **Optiwhite™** is an extra clear float glass, free from the green cast inherent to ordinary float glass. It is used both as an end product and as a semi-finished product for the production of other glass products. It is also used for the production of solar panel components in the dynamically developing market of solar collectors.

Pilkington **OptiView™** is a neutral, anti-reflective coated glass. It reduces light reflection and transmits more light compared to standard float glass with the standard reflectance level of 8%.

NSG **TEC™** is a range of low-emissivity glasses with a pyrolytic on-line electric conductive coating of special qualities. In addition to being used for thermal insulation (stove doors, refrigerator doors), it can also be used after toughening for heating purposes, where the coating acts as a resistor. Since the coating conducts electricity, the electric current travels along the coated surface of the glass. The NSG Group produces various types of glass types belonging to the NSG **TEC™** family with different levels of coating resistance.

The colour of the glass is neutral, while its transparency does not differ much from standard float glass. NSG **TEC™** can be bent, toughened and screen printed.

Pilkington **Insulight™** with ScreenLine® are insulating glass units with integrated blinds (Venetian, pleated or rolled) located between two glass panes. The blind can be controlled manually or mechanically and it does not have any influence on the thermal insulation performance of the insulating glass unit as the blind is located in a fully sealed, insulated space between the panes. Insulating glass units equipped with ScreenLine® blinds provide complete protection against dirt, dust or weather conditions and therefore the blinds do not require cleaning. The wide range of products and the variety of their performance make the Pilkington **Insulight™** insulating glass units with ScreenLine® blinds suitable for all types of frames.

4. Formal basics of glass processing and production of insulating glass units

Since 2007, both insulating glass units and other types of construction glass must be CE marked and compliant with CE mark requirements, which means compliance with European standards for these products. CE marking is one of the key elements of removing trade barriers, it is common for all European Union countries and does not require separate confirmations by individual member states.

All glass units manufactured by all Pilkington IGP Sp. z o.o. plants bear CE marking and Declarations of Performance (DoP) for the products. The CE marking and DoP issued for our products confirm the compliance of the raw materials used, production methods and the factory product quality control system with the European standards applicable to the given type of product:

- insulating glass units, EN 1279 Parts 1–6,
- thermally toughened glass, EN 12150 Parts 1–2,
- thermally toughened heat soaked glass, EN 14179 Parts 1–2,
- thermally heat strengthened glass, EN 1863 Parts 1–2,
- laminated glass, EN ISO 12543 Parts 1–6 and EN 14449.

All glass types used in the manufacturing of our products also bear the CE marking, which confirms compliance with the requirements of the following standards:

- float glass, patterned glass, EN 572 Parts 1–9,
- coated glass, EN 1096 Parts 1–5,
- laminated glass, EN ISO 12543 Parts 1–6 and EN 14449.

As a standard, the CE marking of our products is placed in the upper right corner of the product sticker. The marking is placed on each separate product and on the invoice.

The Declaration of Performance for each product can be downloaded from <https://www.pilkington.com/pl-pl/pl/odbiorcy-szkla/oznakowanie-ce/ce-marking-form>.

To download the document, enter the individual ID number placed on the sticker in the immediate vicinity of the CE mark in the declaration search engine (see: Fig. 2). At the customer's request, we can also deliver the DoP by e-mail or by post.

Supervision over the quality of the products and production processes at Pilkington IGP Sp. z o.o. includes both the control of raw materials, measurement of parameters during processes and statistical control of finished products. The performance and durability of products from all production plants are annually verified by independent laboratories operating within the NSG Group and by external notified certification bodies.

This is confirmed by voluntary certificates of compliance with the standards for individual types of products and additional certificates authorising the company to use marks such as, e.g. BSI, CEKAL, IGCC, held by Pilkington IGP Sp. z o.o. Copies of the current certificates are available at <https://www.pilkington.com/pl-pl/pl/odbiorcy-szkla/certyfikaty-dla-wyrob%C3%B3w-i-wyniki-bada%C5%84>.

Fig. 2. Declaration of Performance example.



Declaration of Performance
CE DoP 13/234417/5



Product

- Pilkington Optilam™ Clear Laminated, 6.8 mm (33.2)
Argon (90%) 16 mm
PilkingtonOptitherm™ ST 1, Annealed, 4 mm
- Applications
for use in construction and civil works, provided that it is installed in accordance with the installation instructions attached to the product documentation
- Harmonised standard
EN 1279-5:2018: Glass in building – Insulating glass units – Part 5: Product standard
- Manufacturer: Pilkington IGP Sp. z o.o.; Sandomierz, ul. Portowa 24
- System of Assessment and Verification of Constancy of Performance (AVCP) 3
- Notified body or bodies, no. 0757, 0086, 1004, 0074
- Declaration of Performance

Essential Characteristics	Specifications
Resistance to fire	NPD
Reaction to fire performance	NPD
External fire performance	NPD
Bullet resistance	NPD
Explosion resistance	NPD
Burglarresistance	P2A+NPD
Pendulum impact resistance	1(B)1+NPD
Resistance against sudden temperature changes and temperature difference	40+40K
Resistance to wind, snow, permanent and imposed load resistance	45/45+45 MPa
Direct airborne sound insulation	NPD
Thermal properties	1.0 W/m ² K
Light and solar properties:	
Light transmittance and reflection	0.71/0.20/0.21
Solar transmittance and reflection	0.40/0.34/0.39
g – value	0.47
Durability	PASS

8. The performance of the product identified in Point 1 is in conformity with the declared performance in Point 7.
This Declaration Of Performance is issued under the sole responsibility of the manufacturer identified in Point 4.
Signed on behalf of the manufacturer by:



Krzysztof Skarbinski
Quality Director Pilkington IGP
01/01/2020

5. Product marking

The standard at Pilkington IGP Sp. z o.o. is permanent marking of products that identifies the manufacturer and temporary marking with individual stickers that provide accurate information about a given product.

Permanent marking of products:

- Insulating glass units are marked with a permanent imprint on the spacer frame inside the glass. The marking contains at least the name of the Pilkington **Insulight™** product, plant identification number, production date and other identifying information, e.g. order number, dimensions, unit structure, etc.
- Laminated glass (single or as a component of an insulating glass unit) have an identification mark with the Pilkington brand logo in the corner and a safety or security class (this does not apply to bulletproof and fireproof panels).
- Toughened glass sheets and heat strengthened glass sheets have permanent marks in the corners, identifying the Pilkington brand logo, as well as the standard and product type name.



Fig. 3. Examples of permanent marking of toughened glass sheets, heat strengthened glass sheets and toughened and heat soaked glass sheets.



Fig. 4. An example of marking on a laminated glass of P4A Class.

It is possible to create a special mark on request, e.g.



Fig. 5. An example of a special marking on toughened glass.

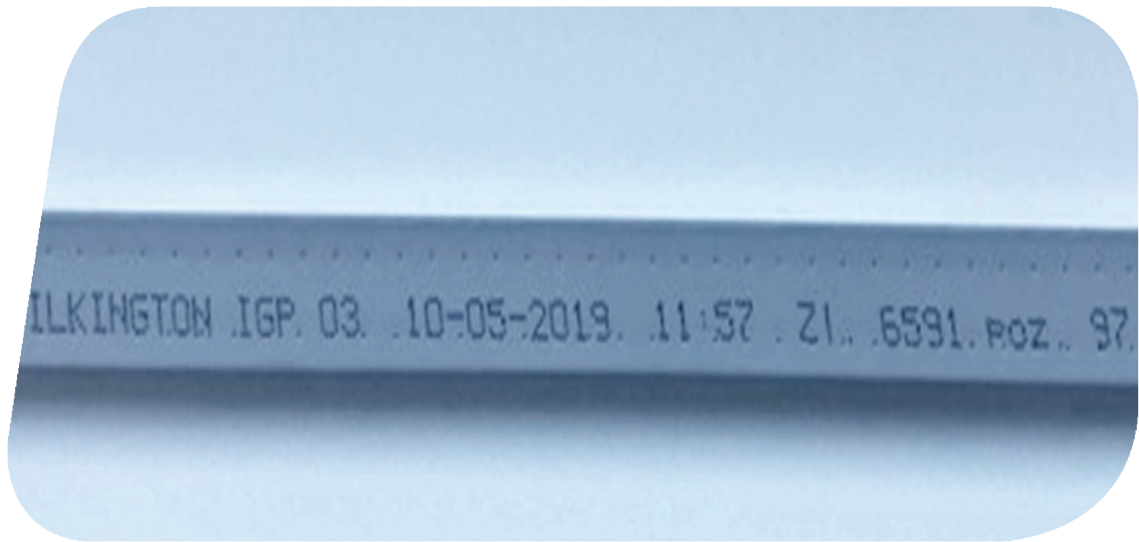

Fig. 6. An example of an imprint on the frame of the insulating glass unit spacer.

Temporary marking with individual stickers:

- Each product is temporarily marked with the main sticker placed on the front side of the glass and a side sticker.
- Both the main and side stickers contain full information about the product enabling the identification of the ordering party, a detailed description of the unit structure, dimensions and weight of the unit, order number, CE marking and the ID number for downloading the DoP. On the side sticker, this information is encoded in a bar code, whereas on the main sticker the full information is provided in writing.
- The main sticker also contains a list of all declared performance parameters of the glass unit that are also given in its DoP.
- Depending on the type of the product and its application, additional stickers are also placed on the glass, informing, for example, which edge of the glass is indicated as the bottom edge when installing in the window or informing that special care must be taken when washing the glass.

Both the appearance and content of stickers and permanent markings can be modified on the clients' request.

Stickers placed on the products are self-adhesive and for the initial period relatively easy to remove without leaving visible traces on the windows. Leaving them on the glass for a long time, especially the main stickers, can make their removal problematic. In such a case, special care should be taken when removing them. Avoid using agents and tools that could scratch the glass.

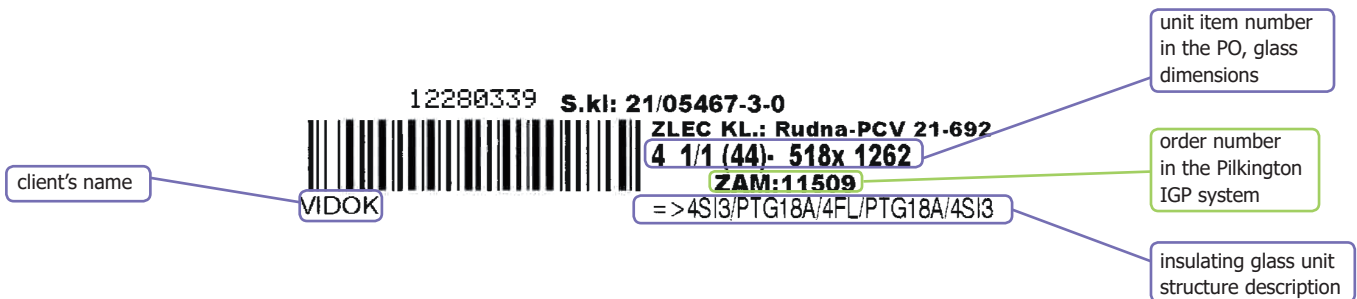
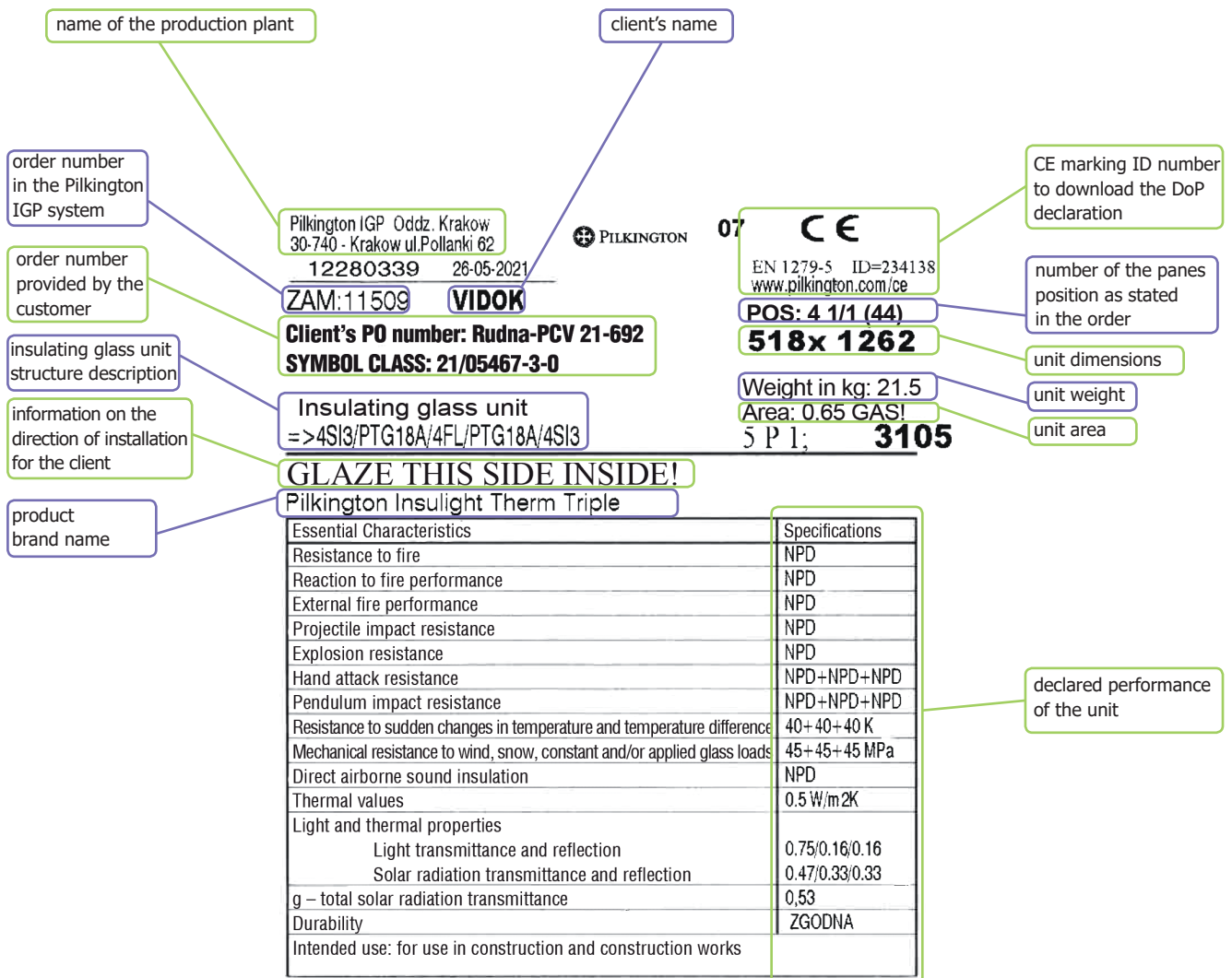

Fig. 7. Example of the main and side stickers with explanations of the information provided.

6. Glass processing

We offer a full range of glass processing services: arrising, grinding, polishing edges; removing coatings, cutting straight and curved shapes, drilling holes, but also toughening, laminating and coated glass with ceramic enamel.

6.1 Edge treatment of the glass edge

The use of glass for decoration has many unique benefits. There are several different solutions to print a pattern, change the colour or to impart a distinctive character to the glass surface, determining the degree of transparency or clarity of the glass. The range of glass products for decorative purposes includes transparent or translucent

products such as screen printed glass, milky film laminated glass, sandblasted glass and patterned glass. Decorative products also include non-transparent products such as enamelled glass and spandrel glass used to clad the area between the windows.

Table 1. Types of processing:

Type of machining	Trade name	Drawing	Picture	Min. dimension in mm	Max dim. in mm, 4 edges	Max dim. in mm, 2 edges
Cross-belt	arrised			200 x 350	3000 x 5920	3000 x 5920
CMS matte finish	CMS matte			300 x 500	2800 x 5920	3000 x 5920
Grinder with Trapezoidal polished finish	Polished			200 x 350	2200 x 3600	2500 x 5920
CMS polished finish	Polished CMS			300 x 500	3000 x 5920	3000 x 5920
C cut – pencil edge	C – edge (Pencil)			150 x 320	1500 x 3500	1500 x 3500

6.2 Cutting out shapes

Pilkington IGP can manufacture glass in both catalogue and non-catalogue shapes and according to customer templates.

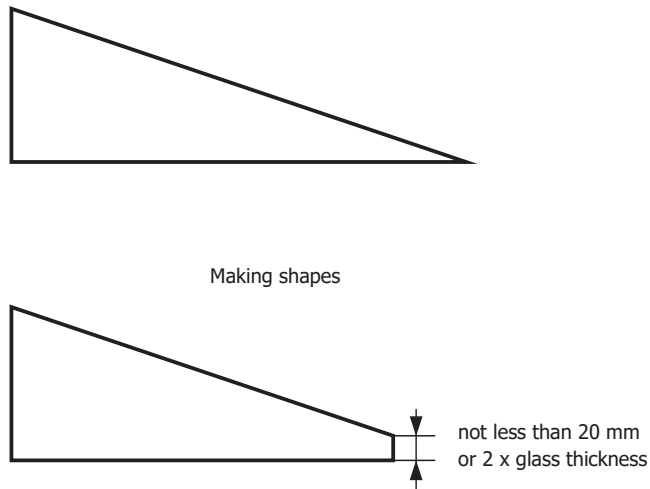

Minimum radius of trapezoidal grinding:

Min. outer radius R1

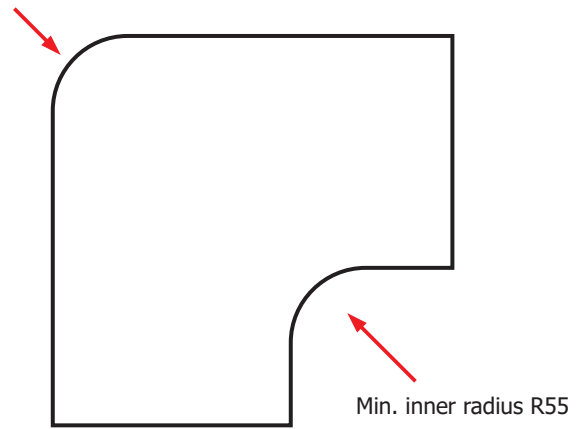

Table 2. Curved shapes machining

Glass thickness	Minimum dimensions in mm	Maximum dimension in mm
4-12 mm	300 x 640	2440 x 2940



6.3 Drilling holes

We offer glass with traditionally drilled holes (diameter 4–60 mm), and milled holes larger than 60 mm. Holes are arised, no grinding inside the hole is done.

Glass thickness	Minimum dimensions	Maximum dimension	Shapes
3-15 mm	200 x 450	2800 x 5920	At least 1 right angle

Table 3. Guidelines for the holes' locations.

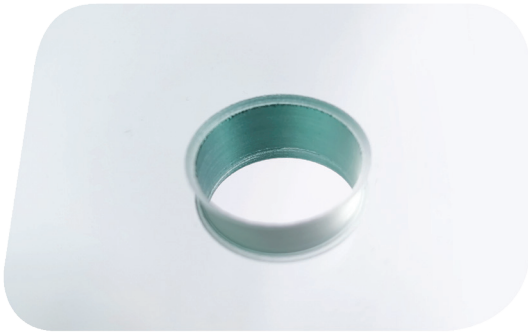

The diameter of the holes should not be less than the glass thickness ($\phi \geq d$)

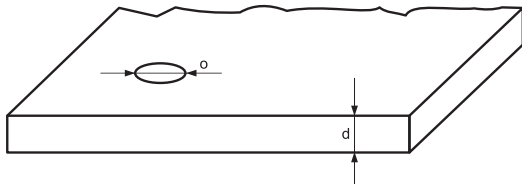

The distance between the holes should be at least 2x glass thickness ($D \geq 2d$)

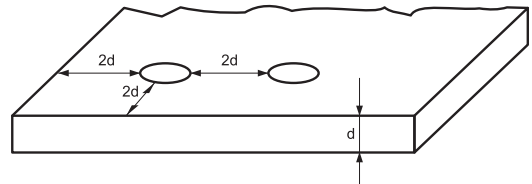

The distance from the edge of the glass should be at least 2x glass thickness ($D \geq 2d$)

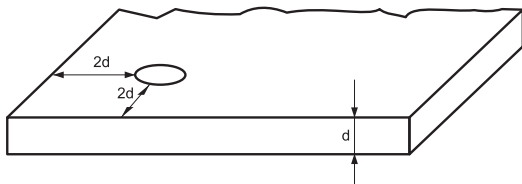

The distance between the hole and the corner should be at least 6 x glass thickness ($D \geq 6d$)

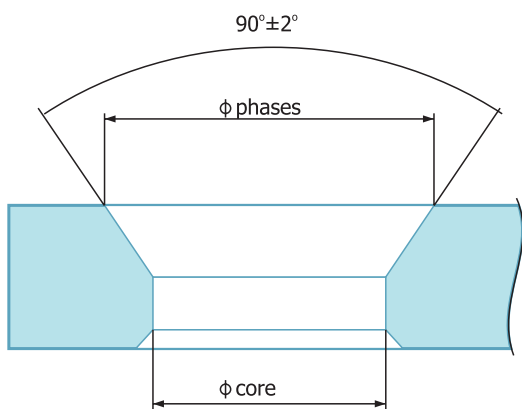
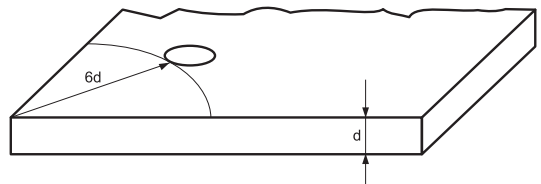

Fig. 8. Cross-section of the hole.



6.4 Locations and limitations of cuts

Undercuts and notches are made in accordance with the system drawing provided by the customer: catalogue and non-catalogue drawing.

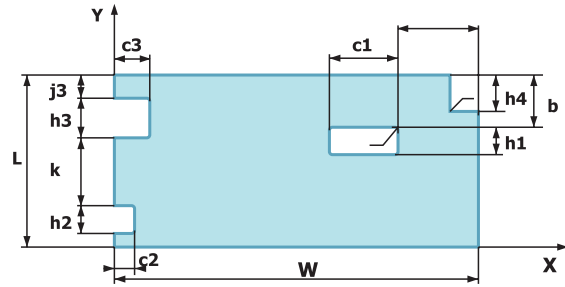

Fig. 9. Locations and limitations of cuts.

7. Lamination

Laminated safety glass consists of two or more individual panes that are laminated together with one or more layers of polyvinyl butyral (PVB) or ionomer SentryGlas® film. Laminated glass produced in Pilkington IGP plants are divided into:

- annealed laminated glass,
- toughened laminated glass,
- laminated heat strengthened glass,
- toughened laminated and coated glass,
- sound-absorbing glass,
- anti-burglary, bulletproof glass,
- glass with SentryGlas® film (ionomer film).

Dimensions:

Maximum lamination dimensions	2700 x 5920 mm
Minimum lamination dimensions	300 x 400 mm
Single glass thickness	2 - 19 mm
Laminated glass thickness	4 - 80 mm
Maximum weight of a single glass	250 kg
Maximum weight of a laminated float glass	500 kg
Maximum weight of a laminated coated glass	350 kg

Table 4. Guidelines for the number of film interlayers.

Single glass thickness	Minimum number of PVB film interlayers		
	Annealed glass	Toughened float glass	Toughened coated, glass depending on the type
4-6 mm	0,38 mm	0,76 mm	1,52 - 2,28 mm
8 mm	0,76 mm	0,76 mm	
10-12 mm	0,76 mm	1,52 mm	
15-19 mm	1,52 mm	1,52 mm	

Table 5. Dimensions for laminated toughened glass.

Glass thickness	Minimum dimensions in mm	Maximum float glass dimensions	Maximum dimensions of hard-coated glass	Maximum dimensions of soft-coated glass
4 mm	300 x 400	1888 x 2850	1500 x 2500	1750 x 2850
5 mm		2000 x 3000	-	2000 x 3000
6-10 mm		2800 x 5920	2800 x 5920	2800 x 5920
12 mm		2500 x 5000	-	2500 x 5000
15 mm		2100 x 3600	-	-
19 mm		2100 x 3600	-	-

Pilkington **Optilam**[™] is offered both as single glass and as a component of insulating glass units with various additional functions – solar control, thermal insulation or acoustic insulation.

Table 6. Classification of laminated glass according to EN 12600.

Nominal thickness of Pilkington Optilam [™] [mm]	EN 12600 classification
4,4	2 (B) 2
4,8	2 (B) 2
6,4	2 (B) 2
(I White) 6,4	2 (B) 2
Pilkington Optiphon [™] 6,8	1 (B) 1
(I White) 6,8	1 (B) 1
6,8	1 (B) 1
8,4	2 (B) 2
8,8	1 (B) 1
Pilkington Optiphon [™] 8,8	1 (B) 1
10,4	2 (B) 2
10,8	1 (B) 1
Pilkington Optiphon [™] 10,8	1 (B) 1
11,5	1 (B) 1
12,4	1 (B) 1
12,8	1 (B) 1
Pilkington Optiphon [™] 12,8	1 (B) 1

Table 7. Classification of laminated glass according to EN 356.

Nominal thickness of Pilkington Optilam [™] [mm]	EN 356 classification
6,8	P2A
Pilkington Optiphon [™] 6,8	P2A
(I White) 6,8	P2A
Pilkington Optiphon [™] 8,8	P2A
8,8	P2A
9,5	P4A
10,3	P5A
10,8	P2A
11	P6B
11,5	P4A
12	P6B
12,3	P5A
12,8	P2A
13,5	P4A
15	P6B
15,8	P2A
16,8	P2A
18,8	P2A
19,5	P6B
20,6	P6B
22,6	P7B
26,8	P3A
27,5	P6B
28	P8B
29,8	P7B
32,1	P7B
39,0	P8B

7.1 Bulletproof glass

Bulletproof glass is a specially selected combination of glass panes of different thicknesses, joined together with films using the lamination process.

We offer bulletproof glass in classes BR2S to BR7S.

Glass type name	Resistance class
Pilkington Optilam [™] 20	BR2S
Pilkington Optilam [™] 24	BR3S
Pilkington Optilam [™] 26	BR4S
Pilkington Optilam [™] 37	BR5S
Pilkington Optilam [™] 46	BR6S
Pilkington Optilam [™] 73	BR7S

7.2 Laminated glass for glass floors and stairs

The Pilkington IGP Sp. z o.o. company offers multilayer laminated glass with PVB to order. The glass may be used to construct floors or stairs for pedestrian traffic.

Since the safety of use and durability of these panels require special care, the guidelines given below should always be taken into account in the design, installation and use of these products:

1. Taking into account the number, thickness, and types of glass layers used for the production of a glass panel, these choices should be based both on the estimated value and type of operational load and the selected method of glass panel support, as well as the maximum load allowed for a given type of glass and the type of load.
2. In floors, it is generally recommended to use linear support along the circumference of a glass panel. The panel cannot be in direct contact with a metal supporting profile and it should be separated from the profile by a hard rubber divider.
3. A typical solution is the use of laminated glass panels consisting of three individual panes of glass with PVB film interlayers. The upper pane is usually made of toughened glass, with an increased resistance to mechanical damage and breakage. The middle and lower glass panes perform the supportive function, which ensures the required durability even if the upper pane breaks.
4. The installation method of a glass floor panel should ensure that only the upper surface of the panel is exposed to mechanical damage during use and that the risk of impact on the glass edges is eliminated. The upper surface of the panel should not protrude above the surrounding elements.
5. The installation method of glass panels should ensure proper drainage along the circumference of the panels so that:
 - there is no rain or washing water on the panels, which could significantly increase the risk of pedestrians slipping;
 - the side edges of the panels do not remain in direct contact with water penetrating into the area of the panel seating.
6. The size of the hole provided for mounting the glass panel should be min. 10 mm greater than the size of the panels, increased by possible panels' production tolerances.
7. In glass floor panels, it should be taken into account that deep scratches may appear much earlier, lowering the aesthetic quality of the glass elements. The scratches may be caused by fine sharp grains of sand and similar materials carried by footwear. As the footwear applies pressure to the grains, mechanical scratches on the glass are produced. The risk of such scratches depends on the area where the panel is placed, pedestrian traffic intensity, type of footwear, and the application of solutions to eliminate the risk of transferring fine grain by footwear.
8. Walking on a flat, smooth surface (such as glass, for example) always carries the risk of slipping and falling. Apart from numerous architectural solutions to reduce the risk of falling when walking on such surfaces, there are also certain technical solutions to apply in order to reduce the risk of slipping on glass floors or steps. An example of such solution is to screen print fine white points during the process of toughening the upper glass pane of the panel. The fine points produced on the surface of the glass panel are durable and have a coarse surface providing better adhesion for footwear. The transparency of a glass panel processed using this technique is not much lower than the transparency of smooth panels. The solution reduces the risk of slipping but cannot fully prevent such accidents from occurring. A decision about the application of this solution has to be made before starting the processing. Another possible solution is to affix a special, coarse anti-slip tape. As the tapes wear out, they require periodic replacement.

7.3 Toughened safety glass and heat-strengthened glass

Pilkington IGP has several production lines for the horizontal toughening of glass. The lines can produce toughened or heat strengthened glass technically from all toughenable glass available on the market, including the latest generation of soft-coated types of glass.

The new generation furnaces have high energy efficiency, ensure

excellent surface properties and maintain strict tolerance values for glass panes:

- toughened,
- toughened and enamelled or with screen printing,
- toughened and heat soaked,
- heat strengthened.

Table 8. Dimensions of toughened glass.

Glass thickness	Minimum dimensions in mm	Maximum float glass dimensions	Maximum dimensions of hard-coated glass	Maximum dimensions of soft-coated glass
4 mm	100 x 250	1888 x 2850	-	1750 x 2850
5 mm		2000 x 3000	2000 x 3000	2000 x 3000
6-10 mm		2800 x 5920	2800 x 5920	2800 x 5920
12 mm		2500 x 5000	2500 x 5000	2500 x 5000
15 mm		2100 x 3600	-	-
19 mm		2100 x 3600	-	-

Table 9. Dimensions of thermally toughened glazing.

Glass thickness	Minimum dimensions in mm	Maximum float glass dimensions	Maximum dimensions of hard-coated glass	Maximum dimensions of soft-coated glass
4 mm	200 x 350	1750 x 2840	-	1700 x 2500
5 mm		2000 x 3000	2000 x 3000	2000 x 3000
6 mm		2800 x 5500	2000 x 3000	2000 x 3000
8 mm		2400 x 4200	2000 x 3000	2000 x 3000
10 mm		2100 x 4200	2000 x 3000	2000 x 3000

Table 10. EN 12600 glass classification

Products family	Thickness [mm]	EN 12600 classification
Float glass	4	1 (C) 2
	6 - 8	1 (C) 2
	10 - 19	1 (C) 1
Coated glass	4	1 (C) 2
	6 - 8	1 (C) 2
	10	1 (C) 1
Patterned glass Pilkington Texture Glass	4	1 (C) 2
	6 - 10	1 (C) 2
enamelled glass	4 - 6	1 (C) 0
	8 - 12	1 (C) 3
etched glass, e.g. Opal	4 - 6	1 (C) 3
	8 - 10	1 (C) 2

7.4 Toughened glass heat soak test

Nickel sulphide (NiS) inclusions in float glass may cause the toughened glass to break spontaneously. Glass panes that contain this contaminant break during the heat soak test performed as an additional production operation, reducing the risk of the glass breakage after installation. Heat soaking of the glass in the HST process does not deteriorate the safety class and strength of toughened glass.

The heat soak test cycle (soaking time) is 120 minutes.

Table 11. Dimensions for glass subjected to HST.

Glass thickness	Minimum dimensions in mm	Maximum float glass dimensions	Maximum dimensions of hard-coated glass	Maximum dimensions of soft-coated glass
4 mm	100 x 250	1888 x 2850	1500 x 2500	1750 x 2850
5 mm		2000 x 3000	-	2000 x 3000
6-10 mm		2800 x 5920	2800 x 5920	2800 x 5920
12 mm		2500 x 5000	-	2500 x 5000
15 mm		2100 x 3600	-	-
19 mm		2100 x 3600	-	-



Fig. 10. View of the toughened glass fracture pattern in which a spontaneous breakage could occur due to NiS inclusion.

8. Screen printed glass and enamelled glass

Pilkington IGP Sp. z o.o. offers customers a wide range of decorative glass, covered with ceramic enamels. The production technology of these panes is based on the even application of ceramic enamel solution over the entire surface of the glass (enamelled glass) or the application of any pattern provided by the client (screen printed glass). In both cases, the glass with the enamel applied is dried and subjected to the glass toughening procedure. As a result, a safety glass is obtained, like other toughened glass, which is resistant to large temperature differences.

Pilkington IGP Sp. z o.o. cooperates with the world's leading suppliers of enamels and pigments to be able to provide enamels in a full range of colours. The range of colourful patterns on glass is limited only by the client's imagination. Cooperation with reputable suppliers guarantees the maintenance of the highest standards in terms of the elimination of heavy metals and other potentially harmful enamel components.

A characteristic feature of enamelled and screen printed glass is the permanent fusion of the glass enamel to the surface of the glass during the toughening process. This guarantees technically unlimited durability of the enamel-glass bonding, and thus high resistance to abrasion and aggressive chemical substances. There is also no risk of the enamel layer peeling off or dissolving during many years of use.

Enamelled glass is mainly used as spandrel glass on building façades. Normally, the glass is installed with the enamel layer facing the façade, so that the non-transparent enamel layer covers the façade surface, insulating materials, etc. located directly behind the glass. The glass installed this way is illuminated only from the outside, which achieves the effect of an even colour of individual panes. It is not recommended to use enamelled glass on walls where the glass is lit from the back. In such conditions, the observer looks at the light transmitted through the enamel and even small local variations in the thickness of the enamel coating may result in unfavourable aesthetic effects. If the customer intends to use the façade glass in a way that does not eliminate the side or back lighting, then we recommend using glass printed with the screen printing technique. This method ensures a very high uniformity of the enamel layer thickness, both over the entire surface of the glass and in the area of the pattern chosen by the client.

As the final colour impressions depend both on the individual perception of the observer and the lighting conditions, location, design solutions, etc., we strongly recommend making decisions based on the assessment of enamelled glass samples, preferably with dimensions that allow assessment in the conditions similar to the conditions at the site of installation.

It should also be taken into account that even the same enamel can provide different visual and colour effects depending on its thickness.

This means that the enamel applied with the enamel technique (thicker layer) provides colour of a much greater intensity compared to the screen printing technique (lower enamel thickness, more translucent).

A general recommendation is to install enamelled and screen printed glass in such a way that the enamel layer faces the interior or the wall of the building. Under such conditions, the enamel is not exposed to the direct, long-term influence of water, rain, dust and air pollution. This method of installing enamelled glass is commonly used and ensures many years of trouble-free use. However, if the enamelled glass must be installed with the enamel outside and directly exposed to the above-mentioned destructive factors, please inform us about that. We also offer enamels characterised by increased resistance to an aggressive environment.

A specific type of enamelled glass are floor panels. People walking on glass floors or steps are at risk of slipping, especially in the presence of even a small amount of water or moisture on the glass surface. The solution to reduce this risk is screen printing with a pointed pattern made of rough, abrasion-resistant enamel. The enamels used for this purpose are milky, translucent, and because they occupy a small percentage of the glass surface, they are often almost imperceptible to the users. The increased anti-slippage properties of this type of glass offered by Pilkington IGP Sp. z o.o. are confirmed by the results of the relevant tests.

Enamelled glass is primarily used for cladding façades. High heat absorption by enamelled glass, combined with the presence of layers of thermal insulation in the building directly behind the glass, causes a very large accumulation of solar heat and the glass heats up to temperatures reaching 80–100°C. Enamelled glass is one of the types of toughened glass, which means that prolonged exposure to highly elevated temperatures increases the likelihood of self-cracking of the glass that may be caused by the excessive nickel sulphide inclusions (NiS). Bearing this in mind, Pilkington IGP Sp. z o.o. recommends performing the HST test for all enamelled glasses that can be exposed to elevated temperatures.

Table 12. Dimensions – enamelling.

Glass thickness	Minimum dimensions in mm	Maximum float glass dimensions
4 mm	100 x 300	1888 x 2850
5 mm		2000 x 3000
6-10 mm		2800 x 5920
12 mm		2500 x 5000
15 mm		2100 x 3600
19 mm		2100 x 3600

Table 13. Dimensions – screen printing.

Glass thickness	Minimum dimensions in mm	Maximum float glass dimensions
4 mm	400 x 700	1888 x 2850
5 mm		2000 x 3000
6-10 mm		2600 x 5200
12 mm		2500 x 5000
15 mm		2100 x 3600
19 mm		2100 x 3600

8.1 Guideline to assess the visible quality of enamelled or screen printed glass, produced by Pilkington IGP

These guidelines apply to assess of visual quality of completely or partially enamelled or screen printed glasses, produced by Pilkington IGP.

Both enamelled and screen printed glasses are produced by burning inorganic colours on glass surface on temperature 620 – 650°C. Pilkington IGP offers two main types of enamelled or screen printed glass:

- toughened safety glass, with or without “heat soak” test
- heat-strengthened glass

Screen printed glass is intended to use both as cladding, and as typical glazing, with viewing of both sides of glass.

The enamelled or screen printed side of glass must always be the side turned away from the weathering and cleaning (position # 2 or higher).

Exceptions are permissible only after prior consultation with the manufacturer.

Applications, with viewing of both **sides must always be agreed with the manufacturer**, since enamelled glass is generally **not** suitable for backlit applications.

General, enamelled glass is intended to use as cladding, to cover walls or facades, and is observed only in reflection light.

8.2 Testing

The visual quality of enamelled glass is checked at a distance of at least 3 meters, in front of an opaque background.

Screen - printed glass is checked in transmitted light at a distance of at least 3 meters, if intended use is viewing from both sides of glass.

Position of observer should be perpendicular to glass surface, with tolerance +/- 30°.

The test is carried out under diffuse daylight conditions (e.g. overcast sky), without direct sunlight or artificial lighting shining directly on the glass or background.

The glazing units in rooms (indoor glazing) are to be inspected with normal (diffuse) illumination intended for the use of the rooms and at a viewing angle that is preferably vertical to the surface.

Viewing should always be done through the untreated glass side onto the enamelled, screen printed glass.

8.3 Allowable discrepancies for the visible quality of enamelled or screen printed glass products

If information, that glass edges are visible, is placed in order - the rebate zone is omitted and the main zone extends to the edge of the glass.

Table 14. The requirements to visual quality of glass products.

Allowable discrepancies for the visible quality of enamelled or screen printed glass products		
Type of Defect	The following are allowable per unit:	
	Main zone	Rebate zone
Point defects*	max 3 pcs, total surface < 25 mm ²	Width: max. 3 mm, exceptionally 5 mm Length: no limit
Hair-line scratches	to 10 mm in length	permissible / no limitation
Clouds, water spots	not allowable	permissible / no limitation
Rests of enamel on the glass edges	-	<ul style="list-style-type: none"> permissible with framed glass panes not allowable with visible edges

* point defects < 0.5 mm ("pin holes") are permissible and are generally not taken into consideration.

Note: Correction of defects in enamel before the toughening process or with organic enamel varnish after the toughening process is permissible. The corrected defects should be not visible from a distance of 3 meters

during test according point 2. However, organic enamel varnish may **not** be used if the glass is further processed into insulation glass and the defect is in the area of the insulation glass sealing edge.

8.4 Assessing the colour impression

Colour deviations cannot in principle be excluded, since they can occur due to several unavoidable factors:

Type of light in which the object is viewed

The light conditions are constantly different depending on the season, time of day and the prevailing weather. This means that the spectral colours of the light are present in varying degrees in the range of the visible spectrum. The colour of enamel could appear a little different, according to the light source.

Viewers and type of viewing

The human eye reacts very differently to different colours. While a very slight colour difference seriously stands out with blue tones, colour differences with green colours are noticed less.

Other factors are:

- the viewing angle,
- the size of the object,
- how closely two objects to be compared are placed to one another,
- colour of background and distance to glass surface.

Please note, even if you prepare enamelled glass and screen printed glass on a base of the same enamel - you could observe deviation of colour impression both glasses, due differ thickness of enamel layer's on glass surface,

8.5 General comments

- ▶ The other characteristics of the products (for example: tolerance of dimension, flatness, mechanical strength) are conform with the respective European standards:
 - EN 12150-1 for toughened safety glass
 - EN 1863-1 for heat-strengthened glass
 - EN 14179-1 for toughened safety glass with HST.
- ▶ Applications enamelled or screen printed glass as a part of laminated safety glass must be checked with the manufacturer. That applies in particular to use of etching tone enamels, since during laminating the optical density of the etching tone can be severely reduced and the effect of the etching tone is preserved only with use on position 1 or 4.
- ▶ Special colours, e.g., metallic effect, anti-slip coatings or combinations of several colours can be produced on request. The respective special characteristics or the appearance of the product are to be clarified with the manufacturer.
- ▶ Enamelled or screen printed glass can only be manufactured as toughened safety glass or heat-strengthened glass.

Any further mechanical treatment of enamelled or screen printed glass is not permissible, for example: grinding, polishing of edges; drilling holes.

- ▶ Enamelled or screen printed glass can be used as monolithic glass or as a part of insulating glass unit. In this case, the respective provisions, standards and guidelines are to be taken into consideration by the user.
- ▶ Enamelled or screen printed glass can be heat-soak tested /HST/ to reduce risk of glass self-breaking. The respective necessity of the heat-soak test is to be checked by the user and disclosed to the manufacturer by putting the order.
- ▶ The statics parameters of enamelled or screen printed glass are lower at non-printed or non-enamelled equivalent glass.

9. Tolerances and acceptable defects for toughened, heat soaked toughened, heat strengthened glasses and for laminated glass – according to relevant European standards

9.1 Glass sheets without edge processing

Longest Dimension	Tolerance			
	Nominal thickness $\leq 8\text{mm}$		Nominal thickness $> 8\text{mm}$	
	Dimensional (width/length)	Diagonals	Dimensional (width/length)	Diagonals
$\leq 2000\text{ mm}$	$\pm 2,0$	≤ 4	$\pm 3,0$	≤ 6
$> 2000\text{ mm} \leq 3000\text{ mm}$	$\pm 3,0$	≤ 6	$\pm 4,0$	≤ 8
$> 3000\text{ mm}$	$\pm 4,0$	≤ 8	$\pm 5,0$	≤ 10

Table 15. Dimensional (width/length).

Entrant end emergent faults – surface view	Entrant faults – edge view	Bevel – edge view
		
Edge defect	Limitations	
Entrant fault	$h_1 < (e-1)\text{ mm}$ $p < (e/4)\text{ mm}$	
Emergent fault	h_2 – shall not exceed the positive tolerance t depending on glass production type and the glass shall remain within the rectangle resulting from nominal dimensions, i.e. H and B with positive tolerance	
Bevel	The ratio (d/e) shall be less than 0.25	

Table 16. Edge defects – glass sheets without edge processing.

9.2 Toughened, heat soaked toughened, heat strengthened glass

Dimensional tolerances – see: Table on page 29.

Product	Maximum allowable value for distortion		Edge lift	
	Overall bow mm / m	Roller wave mm	Thickness 4-5 mm	Thickness 6-19 mm
All glasses	3,0 mm/m	0,3 mm	0,4 mm	0,3 mm

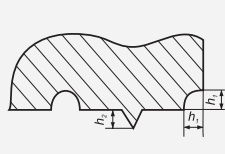
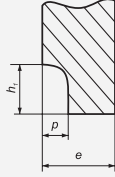
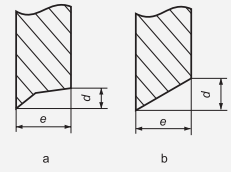
Table 17. Overall bow, roller wave, edge lift.

Scratches	Scratches	Scratches
Hair line Scratches	Allowed, but not concentrated < 25mm / 4 per metre	Allowed, but not concentrated One ≤ 12mm
Point defects (pin holes)		
< 0,5 mm	Allowed	Allowed
≤ 1,0 mm	Allowed not in clusters	Allowed not in clusters
≤ 2,0 mm	Allowed 1 per metre	2 per m ² / maximum 4
> 2,0 mm	Not allowed	Not allowed

Table 18. Spot and linear defects.

Nominal hole diameter, Ø, [mm]	Tolerances [mm]
$4 \leq \text{Ø} \leq 20$	±1,0
$20 < \text{Ø} \leq 100$	±2,0
$100 < \text{Ø}$	Consult the manufacturer

Table 19. Tolerances on hole diameters.

Between the hole and the glass edge	Between two holes	Between hole and corner of glass
 <p>$a \geq 2d$</p>	 <p>$b \geq 2d$</p>	 <p>$c \geq 6d$</p>

Table 20. Limitations for position of holes.

9.3 Laminated glass

Thickness – sum of the thicknesses of the glass panes and interlayers

Interlayers:

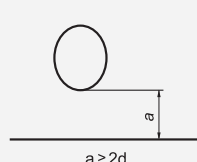
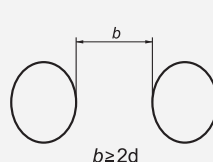
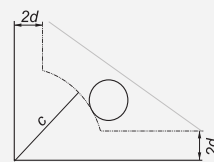
for the total thickness ≤ 2 mm the additional limit deviation is $\pm 0,1$ mm, otherwise it is $\pm 0,2$ mm

Glass:

limit deviations for float:

3-6 mm is $\pm 0,2$ mm,

8-12 mm is $\pm 0,3$ mm.

Nominal dimension L or H	Nominal thickness of laminated glass ≤ 8 mm	Nominal thickness of laminated glass > 8 mm	
		Each glass pane < 10 mm nominal thickness	At least one glass pane ≥ 10 mm nominal thickness
≤ 2000 mm	+3,0 -2,0	+3,0 -2,0	+5,0 -3,5
≤ 3000 mm	+4,5 -2,5	+5,0 -3,0	+6,0 -4,0
> 3000 mm	+5,0 -3,0	+6,0 -4,0	+7,0 -5,0

Table 21. Limit deviations on width L and length H.

Nominal dimension L or H	Maximum permissible displacement d
$L, H \leq 1000$	2,0
$1000 < L, H \leq 2000$	3,0
$2000 < L, H \leq 4000$	4,0
$L, H > 4000$	6,0

Table 22. Maximum displacement.

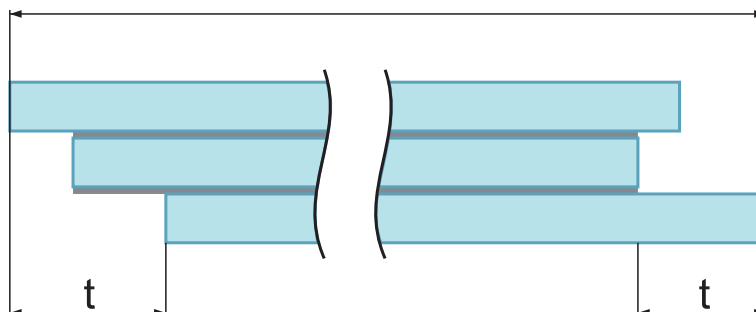

Size of defect d [mm]		0,5 < d ≤ 1,0	1,0 < d ≤ 3,0			
Size of glass A [m ²]		For all sizes	A ≤ 1	1 < A ≤ 2	2 < A ≤ 8	A > 8
Number of density of permissible defects	2 panes	No limitation, however no accumulation of defects	1	2	1/m ²	1,2/m ²
	3 panes		2	3	1,5/m ²	1,8/m ²
	4 panes		3	4	2/m ²	2,4/m ²
	≥ 5 panes		4	5	2,5 m ²	3 m ²

Table 23. Permissible spot defects in the vision area - spot defects.

Area of glass [m ²]	Number of permissible defects >30 mm in length ^a
≤ 5	Not allowed
5 to 8	1
> 8	2

A linear defects less than 30 mm in length are allowed

Table 24. Number of permissible defects in the vision area – linear defects.

Note 1: Above tolerances do not refer fire resistant glasses.

Note 2: If one of the component of the laminated glass is a toughened or heat-strengthened glass an additional tolerance for them shall be taken into account.

Note 3: Defects should be evaluated from a distance at least 2 m with the glass in vertical position and under diffuse daylighting conditions.

10. Insulating glass units

The main purpose of insulating glass units is to ensure the long-term good visibility and lighting of rooms, while reducing heat loss and/or heating rooms, as well as improving acoustic comfort and safety. To obtain all of the above functional features, a unit consisting of two or three separate panes with special coatings must be constructed. Maintaining the insulating qualities of the insulating glass units over the many years of their use depends primarily on the durability of the seal applied around the perimeter of the units. The sealing around the perimeter of the unit is applied to maintain the long-term airtightness of the inter-pane spaces in order to:

- Protect it against the penetration of water vapour causing corrosion and degradation of internal coatings on the glass as well as indelible, visible dirt inside the unit.
- Protect it against leakage of the gas used to fill the inter-pane spaces (usually neutral argon), used to improve thermal insulation.

The production of insulating glass units has a long tradition and such units are found almost everywhere around us. The dominant type of insulating glass units in the world are solutions based on a two-stage system of sealing the perimeter of the insulating glass unit. In these solutions, butyl is applied on both sides on the spacer separating the individual panes, so that after inserting the spacer between the panes and pressing them, the butyl forms a tight connection between the panes and the spacer. Then, along the unit edge, a second sealing compound is applied, completely filling the space between the spacer and the edges of the individual panes of the unit.

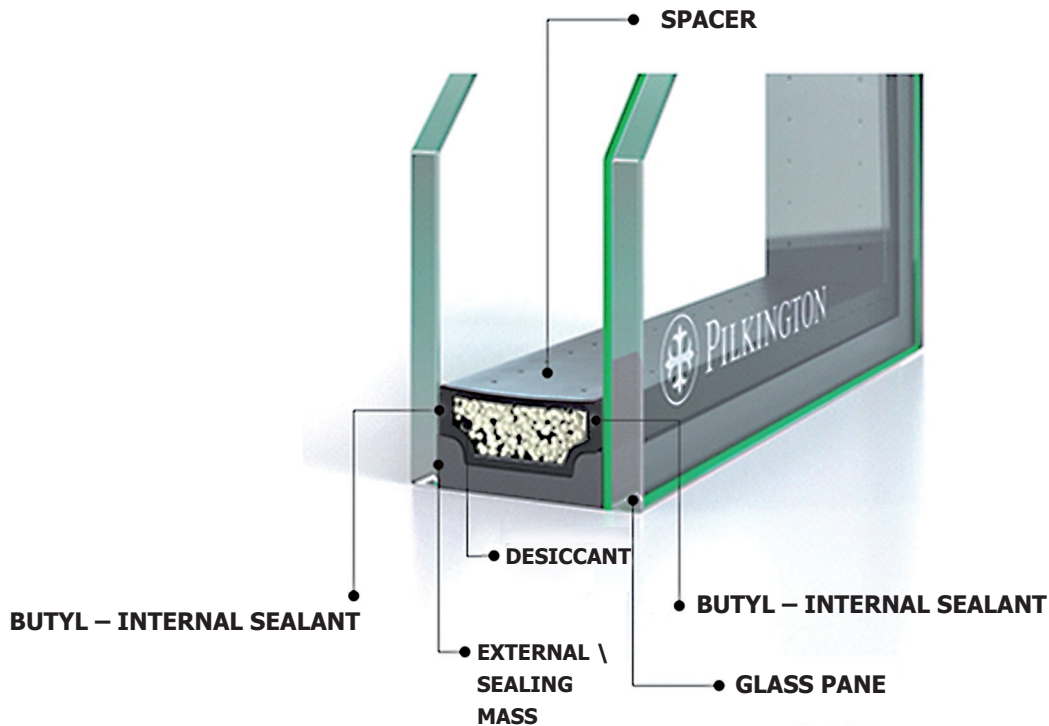

Fig. 11. Construction of the insulating glass unit.

Pilkington **Insulight™** Therm insulating glass unit

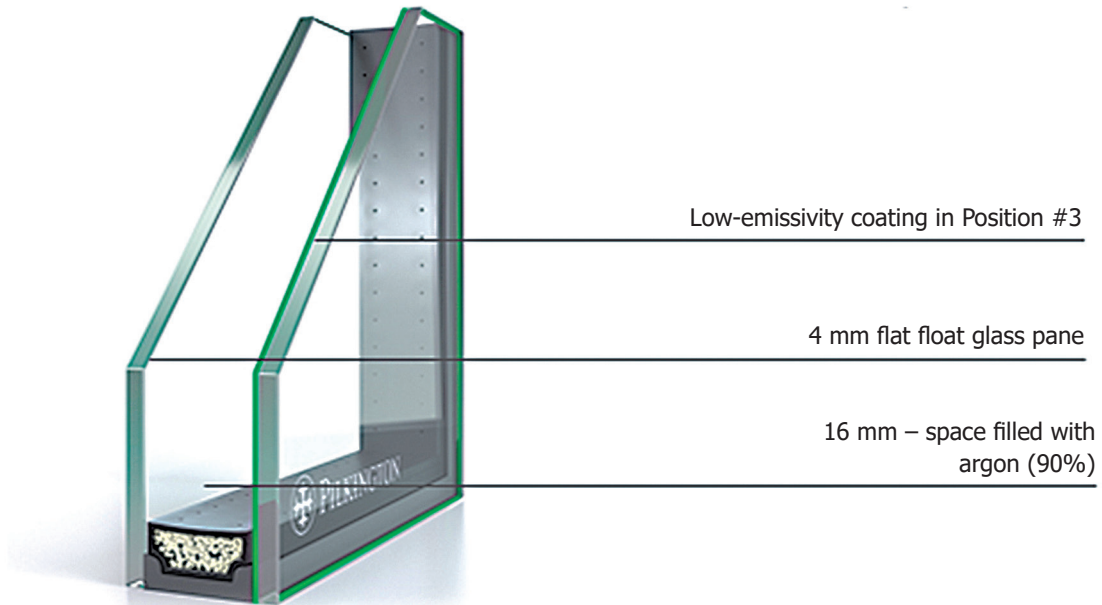

Fig. 12. Low-emissivity double glazed insulating glass unit.

Pilkington **Insulight™** Therm Triple triple glazed insulating glass unit

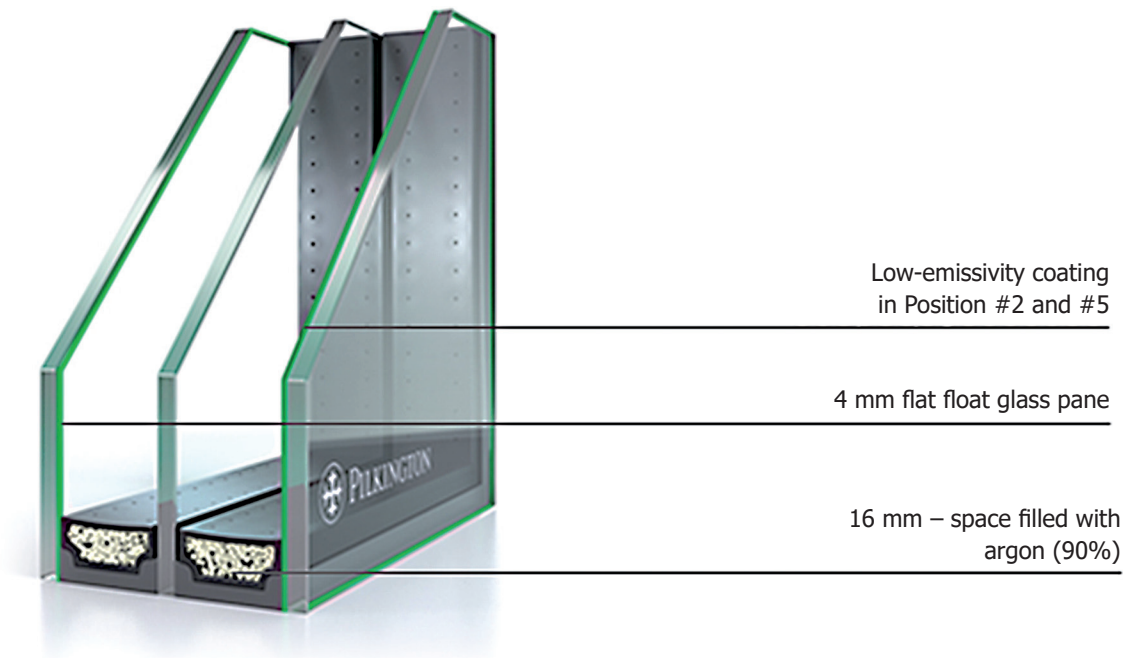

Fig. 13. Low-emissivity triple glazed insulating glass unit.

10.1 Insulating glass unit with integrated blinds

Pilkington **Insulight™** with ScreenLine® blinds are insulating glass units with integrated blinds located between two glass panes. ScreenLine® blinds can be used in double glazed and triple glazed units. The blinds can be controlled manually or mechanically, which does not have any influence on the thermal insulation performance of the insulating glass unit as the blind is located in a fully sealed, insulated space between the panes.

The ScreenLine® blind inside the unit provides very good protection against the sun as the sun's radiation is reflected before entering the room.

The use of blinds inside the insulating glass units significantly reduces the total transmittance of solar energy. Insulating glass units with ScreenLine® provide complete protection against dirt, dust or weather conditions and therefore the blinds do not require cleaning.

The wide range of products and the variety of their performance makes Pilkington **Insulight™** with ScreenLine® suitable for all types of frames. Pilkington **Insulight™** with ScreenLine® comply with the PN-EN 1279-5 standard, and ScreenLine® blinds meet the quality criteria set out in Annex 5.

Offered systems:

- SL22C system (and SL22C U-size) or SL27C – Venetian blinds with a string or a manual knob control. Depending on the system, the width of the spacer is 22 mm or 27 mm.



Offered systems:

- SL22MB or SL27MB system – Venetian blinds with an internal electric motor, controlled by a button or a remote control.

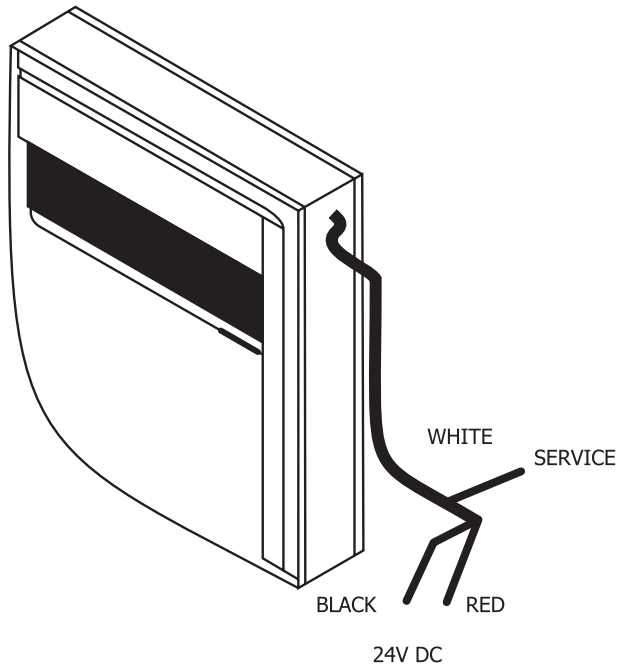



Offered systems:

- SL22W Smart system (and SL22W Smart U-size) – Venetian blinds with an internal motor powered from batteries charged by a charger or by a photovoltaic cell.

Types of spacers:

For 22 mm wide systems

- grey “warm” spacer
- black “warm” spacer

For 27 mm wide systems

- silver aluminium spacer
- black aluminium frame



Available lamels colours:

lamels colours:	
S102	White
S149	Cream
S157	Silver
S106	Yellow
S125	Beige
S130	Light green
S142	Light blue
S155	Light grey
S156	Metallic silver



10.2 Spacers types

The following profiles are used for the production of spacers: aluminium, galvanised steel, stainless steel, “warm” plastic. The spacers are available in a length of 6 m, widths of 6–32 mm and heights of 6.5–7 mm.

The thermal insulation of Pilkington **Insulight™** insulating glass units can be improved by using thermally enhanced spacers (so-called “warm” spacers). The spacers are usually made of a plastic or fibreglass closed profile that has a thin steel or aluminium foil on the back wall.

Plastic is characterised by a very low thermal conductivity index, which reduces the heat loss on the edges of the insulating glass unit, whereas steel or aluminium foil strengthens the spacer and improves the unit integrity. Warm spacers improve the value of the U_w factor for the entire window.

10.3 Muntins

Muntins are used as an imitation of window frames inside the insulating glass units. Two types of muntins are used by Pilkington IGP:

- muntins that require edge milling before folding,
- muntins that do not require edge milling before folding.

To attach the muntin to the spacers, rivets or metal staples shot with a pneumatic gun and plastic connectors are used. In places where the muntins cross, self-adhesive colourless silicone strips (so-called “bumpons”) are normally used or other similar solutions with a thickness selected so that they do not come into contact with the glass.

Their role is to minimise the risk of vibration of the muntins and knocking of the muntin against the glass surface when the window or the door is suddenly opened. They also have aesthetic functions. Silicone rings are used for all types of muntins, except for veneered muntins and Viennese muntins, intended for windows equipped with external decorative strips. In Viennese-type muntins intended for windows with external decorative strips, short silicone strings, felt discs or silicone plugs are used as vibration damping elements.

Viennese muntins should be used in the space between the glass panes, a leaving min. 2 mm distance on each side between the muntin and the glass surface. When making arches, the Viennese muntin is made of two spacers with a minimum bending radius of $R \geq 70$ mm. When ordering insulating glass units intended for gluing external muntins, the glass deflection caused by weather conditions (temperature, pressure) should be taken into account and allowed for in the design

assumptions. This will ensure the appropriate thickness of the glass panes specified in the order and correct installation and operation of this type of insulating glass units. When sticking external muntins on the glass, one should remember to use a suitable adhesive (soft weatherproof silicone is recommended), which bonds the pane with the external muntin, ensuring a distance of min. 4 mm.

Table 25. Installation of internal and external muntins.

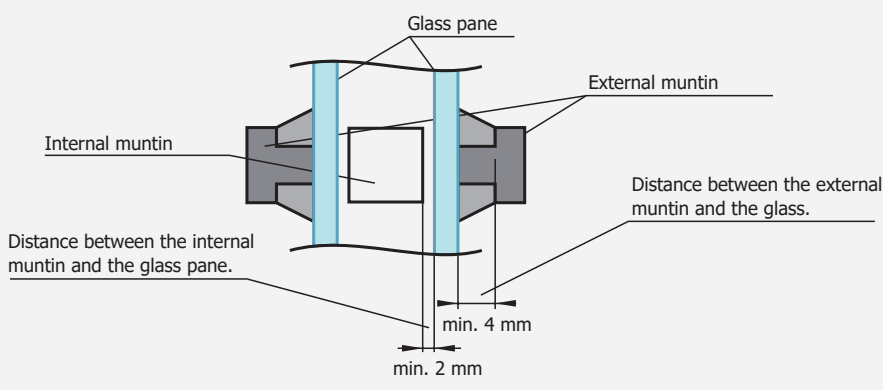

When using inter-pane muntins, it is possible to:

- create curved fields, taking into account the minimum bend radius:

For 8 mm wide muntin	$R \geq 80$ mm (arch only)**
For 18 mm wide muntin	$R \geq 170$ mm
For 26 mm wide muntin	$R \geq 200$ mm
For 45 mm wide muntin	bending not possible

- various combinations of joining the width of the muntins,
- various combinations of joining the muntins bent at different angles,
- joining the muntins at different angles (examples are included in the muntins' offer).

** it should be remembered that the 8 mm muntin is connected by means of overlays and in the case of joining the arch with a straight section, the bending radius should be $R \geq 160$ mm.

Base muntin / Connector	8 mm	18 mm	26 mm	45 mm	Maximum area [mm]
8 mm	+	-	-	-	700 x 700
18 mm	-	+	+	-	1200 x 1200
26 mm	-	+	+	-	1200 x 1200
45 mm	-	+	+	+	1200 x 1200

For DUPLEX/Viennese muntins, the maximum permissible area must not exceed 1200 mm.

10.4 Guidelines for the use of Georgian bars in Insulating Glass Units

In order to avoid the risk of dissatisfying customers as to the quality of our products, do not accept orders for IGUs (double or triple) with Georgian bars, if the IGU's spacer width is not, at the minimum, 4 mm bigger than the bar thicknesses.

Practically speaking, it means that:

- for the golden, silver or white bar (8 x 1.5 mm), the spacer width should be ≥ 12 mm;
- for the normal or milled bar (1808, 2608, 4508), the spacer width should be ≥ 12 mm;
- for the "Wiener sprossen" 9.5 mm thick, the spacer width should be ≥ 12 mm
- for the "Wiener sprossen" 11.5 mm thick, the spacer width should be ≥ 15 mm.

The above restrictions arise from the need to avoid potential complaints due to the reduction of thermal insulating of a IGU in the Georgian bar area. It may display itself as the frost penetration of unit in the bar area or moisture condensation on the glass surface along the bars. In extreme cases, you run the risk of cracking glass or „bumpons,” which is caused by the direct pressure of the glass on the bar.

The maximum spacing between the bar anchor points or between the anchoring and cross, alternatively – between two crosses – should not exceed 0.7 m. For spacing above 0.7 m, inform the customer of the risk that the Georgian bars could bend and vibrate, further – inform the customer of Pilkington IGP guidelines.

The standard procedure for Pilkington IGP plants is to stick transparent „bumpons” where bar cross. The function of „bumpons” is to reduce the so-called effect of muntin „ringing,” which occurs in certain situations. The thickness of self-adhesive silicone „bumpons” manufactured by 3M™ is so adjusted that they are as big as possible but do not touch the glazing. „Bumpons” are not glued to bars covered with „Renolit” foils.

It means that for bars with the thickness of 8 mm, that is the milled (1808, 2608, 4508), golden, silver and white ones, the thicknesses of bumpon should be:

- ≤ 2 mm for the spacer 12 mm, (recommended SJ-5382, thickness – 1.8 mm, diameter – 6.4 mm)
- ≤ 2.5 mm for the spacer 14 mm, (recommended SJ-5302A, thickness 2.2 mm, diameter – 6.4 mm)
- ≤ 3.5 mm for the spacer ≥ 16 mm, (recommended SJ-5378, thickness – 3.2 mm, diameter – 7.9 mm)

Orders for IGUs in which the difference of the spacer and bar thicknesses does not exceed 4 mm may be accepted only on the customer's own responsibility, having informed them of negative effects inherent to such a solution, with the observance of the aforementioned principles for the selection of bumpon thicknesses.

10.5 Gases

The application of sealing compounds around the perimeter of an insulating glass units creates a hermetically closed space between the adjacent glass panes. Under normal conditions, this space is filled with air surrounding the glass production line. However, the insulating glass units manufactured by Pilkington IGP Sp. z o. o. have been filled with argon as standard for many years now. Argon - a noble gas, completely inert and harmless for people and the environment, is heavier than air, and thus provides greater thermal insulation of glass units. The use of argon reduces the U-factor, and thus limit heat loss from the rooms. On request, Pilkington IGP Sp. z o.o. can also produce insulating glass units filled with another noble gas - Krypton. Like argon, it is completely inert and harmless, and because it is even heavier than argon, it ensures further reduction of heat transfer.

Pilkington IGP Sp. z o. o. normally fills the insulating glass units with gas on an automatic production line, as a part of glass pressing operation. This process of filling the units with inert gas does not result in any changes in the appearance of the glass and spacers that are visible to the client. The presence of gas can be detected with a special gauge only. In very few cases, e.g. in production of glass units of small dimensions or very unusual shapes, the gas filling process may not be automatic. In such cases, the glass units are filled with gas through two holes with a diameter of approx. 4 mm, drilled in the spacer frame, and closed with plugs once the process is finished. These plugs are grey in colour and may be visible on the spacer. This is usually not a problem for the user as this area is in most cases covered by the window frame.

Table 26. Gases used

Argon	Glass unit filed up to 90 +10/-5%
Krypton	Glass unit filed up to 90 +10/-5%
Combination of Argon and Krypton	per client's request.

10.6 Sealing compounds

Permanent connection of the unit glass panes is achieved by the application of sealing compounds around the perimeter of the unit. Sealing compounds, also called sealants, are designed not only to hermetically bond individual glass panes to the spacer, but also to compensate the loads that occur in the insulating glass units during use. The sealing compounds constitute a barrier preventing the penetration of water vapour and gases into or from the insulating glass unit.

Pilkington IGP Sp. z o.o. produces insulating glass units equipped with a double sealing system: internal and external sealing.

Butyl is used as the internal sealing compound. Butyl is a durable thermoplastic compound applied to both sides of the spacer that separates the individual panes. Due to its excellent adhesion to both glass and metal, butyl provides a tight connection between the glass panes and the spacer, and is also an excellent barrier to stop the penetration of water vapour and to prevent the gas used to fill the chambers of the insulating glass unit escaping. In a complete insulating glass unit, butyl is visible in the form of a few millimetre wide black band on the side walls of the spacer.

The second, external sealing compound are permanently-elastic masses from the group of polyurethanes, polysulfides or silicones. Due to their strong adhesion to glass and their durability, they ensure durability and tightness of the units.

All sealants are black as standard. After installing the insulating glass unit in the window frame, both the butyl and the external sealing compound are hidden in the frame and virtually invisible.

Polyurethane and polysulphide sealing compounds are used for insulating glass units installed with the traditional installation method, i.e. when the units are mechanically fixed in the window frame and the edges of the glass panes are covered with window strips around the perimeter. This solution provides protection of the sealing compound against UV radiation, which may cause gradual degradation of the organic components of the compound.

In solutions where the method of fixing the units does not ensure the protection of the glass edges against UV radiation along the entire perimeter, Pilkington IGP Sp. z o.o. offers insulating glass units sealed with special two-component silicones delivered by reputable suppliers. These silicones can act as a construction sealant, making it possible to construct all glass façades.

Regardless of the chosen method of glass installation and the type of sealants used, it is necessary each time to consider the risk of undesirable chemical reactions occurring in direct contact between the adhesives, silicones, gaskets and other materials used for installation of the unit in the window and the compound used for sealing the panes in the unit. This problem, known as "compounds incompatibility", often leads to irreversible damage to the unit. Pilkington IGP Sp. z o.o. recommends clients check the compatibility each time when choosing materials for glazing. The company also declares assistance in performing verification tests.

10.7 Using construction sealant for sealing insulating glass units

Construction sealants are durable, flexible and resistant to UV radiation, oxygen, ozone and temperature changes. They have excellent adhesion both to glass and metal spacers. They are resistant to water, steam and weather conditions. They can withstand 2000 h of UV radiation. They do not contain organic plasticisers. They are recommended for glazing and structural joints. They can be used both as internal and external sealants at temperatures up to 100°C and in high humidity conditions.

According to EN 1279-1, silicone is used in insulating glass units:

- a) when the insulating glass units are used for installation with at least one edge not completely protected against direct UV radiation without a constant shear load in the sealant,
- b) when the insulating glass units are glued to doors, windows and curtain walls with possible permanent shear load in the sealant with or without exposure to direct UV radiation. In this case, there are no mechanical joints, and the only bonding and fixing element is the silicone sealant.

The most frequently offered solutions with the use of silicone are:

- a) Insulating glass units sealed with silicone and equipped with so called "U-profiles" glued into the structure

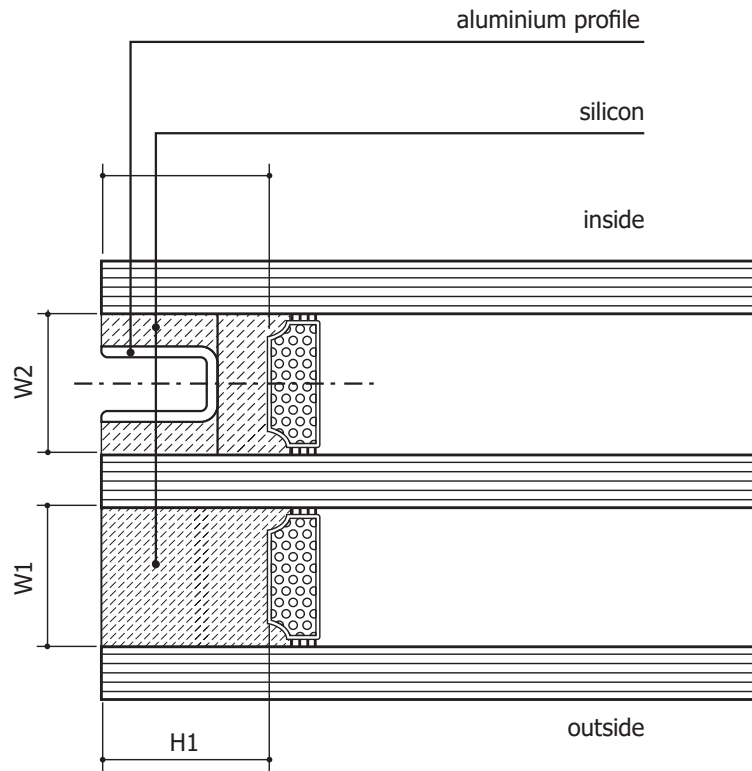

- b) Insulating glass units used for "glass corners"

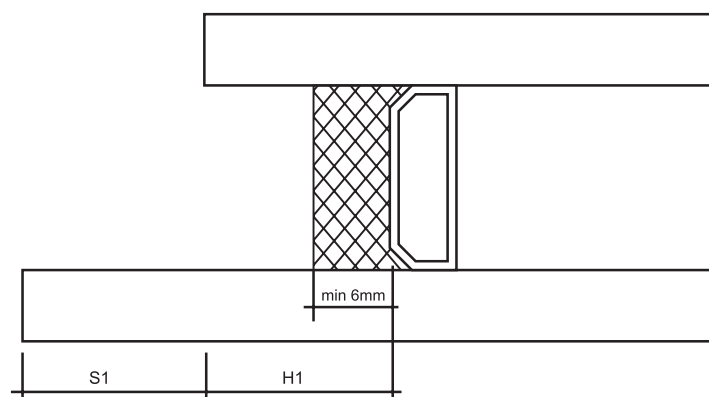

c) Insulating glass units sealed with silicone

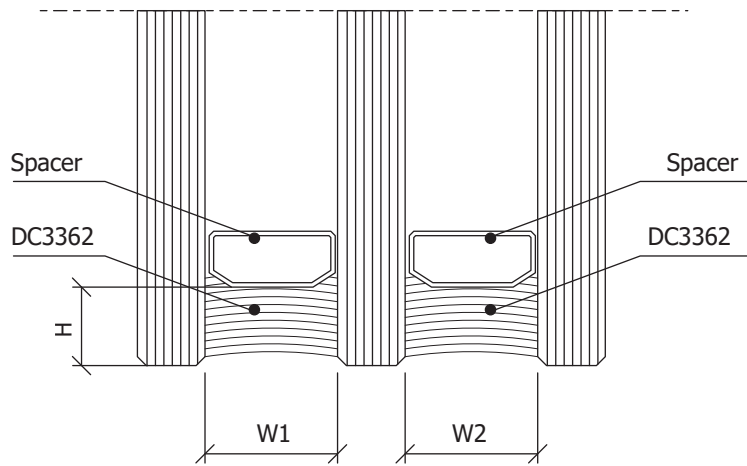

d) Insulating glass units fixed to the structure with silicone

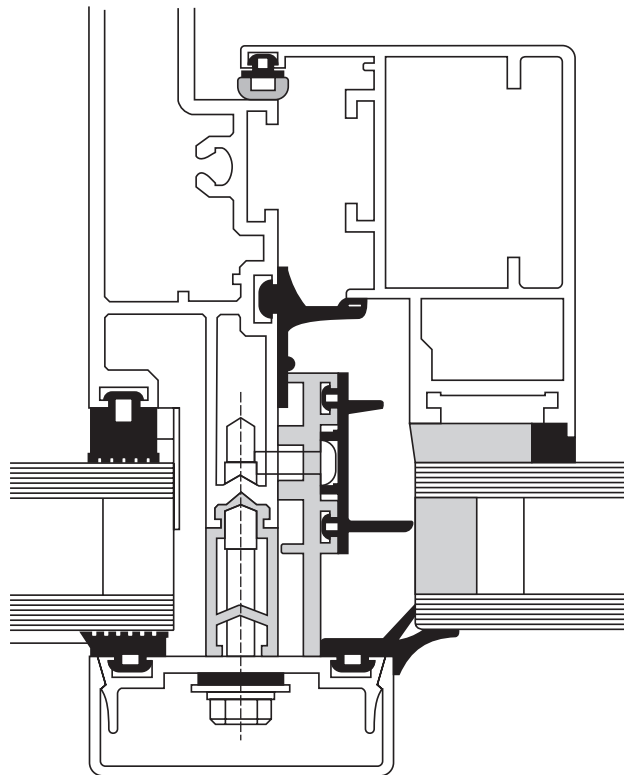

Each order for insulating glass units with the use of silicone must be accompanied by a signed document containing the sealant manufacturer's recommendation regarding the minimum dimensions of the silicone joints.

The silicone manufacturers have appropriate tools to determine the required dimensions of the silicone joint and guarantee the durability and safety of the joint if properly selected.

10.8 Insulating glass units intended for use in mountain areas

Standard insulating glass units work well at elevations equal to or close to the location they were manufactured.

Depending on the structure and dimensions of the glass, we do not recommend installation at the height of 650 m above sea level or higher, and in extreme cases, even at the height of 400 m above sea level. If this height is exceeded, the insulating glass units should be treated as installed in a "mountain area".

The lower atmospheric pressure at higher altitudes causes a significant overpressure in the insulating glass unit chambers, leading to a reduction in the durability of the glazing seal, convexity, and in extreme cases, even to glass cracking. Due to the variety of types, thickness and dimensions of individual glass panes installed in insulating glass units, it is not possible to indicate a specific height above sea level, which is the limit for the use of standard insulating glass units.

In such situations, Pilkington IGP offers insulating glass units with the internal pressure adjusted to the pressure at the intended location of

mounting. These decisions should be made individually on the basis of calculations of the stress level in the glass. Particular attention should be paid to triple glazed insulating glass units, which, due to the double volume of internal chambers, are more susceptible to this phenomenon.

Reduction of the gas pressure in the inter-pane space is done during the production of the units by means of a small additional hole drilled in the spacer. The drilled hole is plugged with a rubber valve (Fig. 14). Tight closure maintains the appropriate pressure inside the unit and prevents its excessive swelling at the lower atmospheric pressure. In terms of aesthetics, this solution is similar to the appearance of the holes in insulating glass units manually filled with gas. Insulating glass units for mountain area applications are offered with all types of spacers, the width of which is at least 10 mm. When placing orders for this type of units, it is necessary to clearly note that the units are to be installed in a mountain area. The approximate elevation above sea level at which the insulating glass units are going to be installed should also be provided.

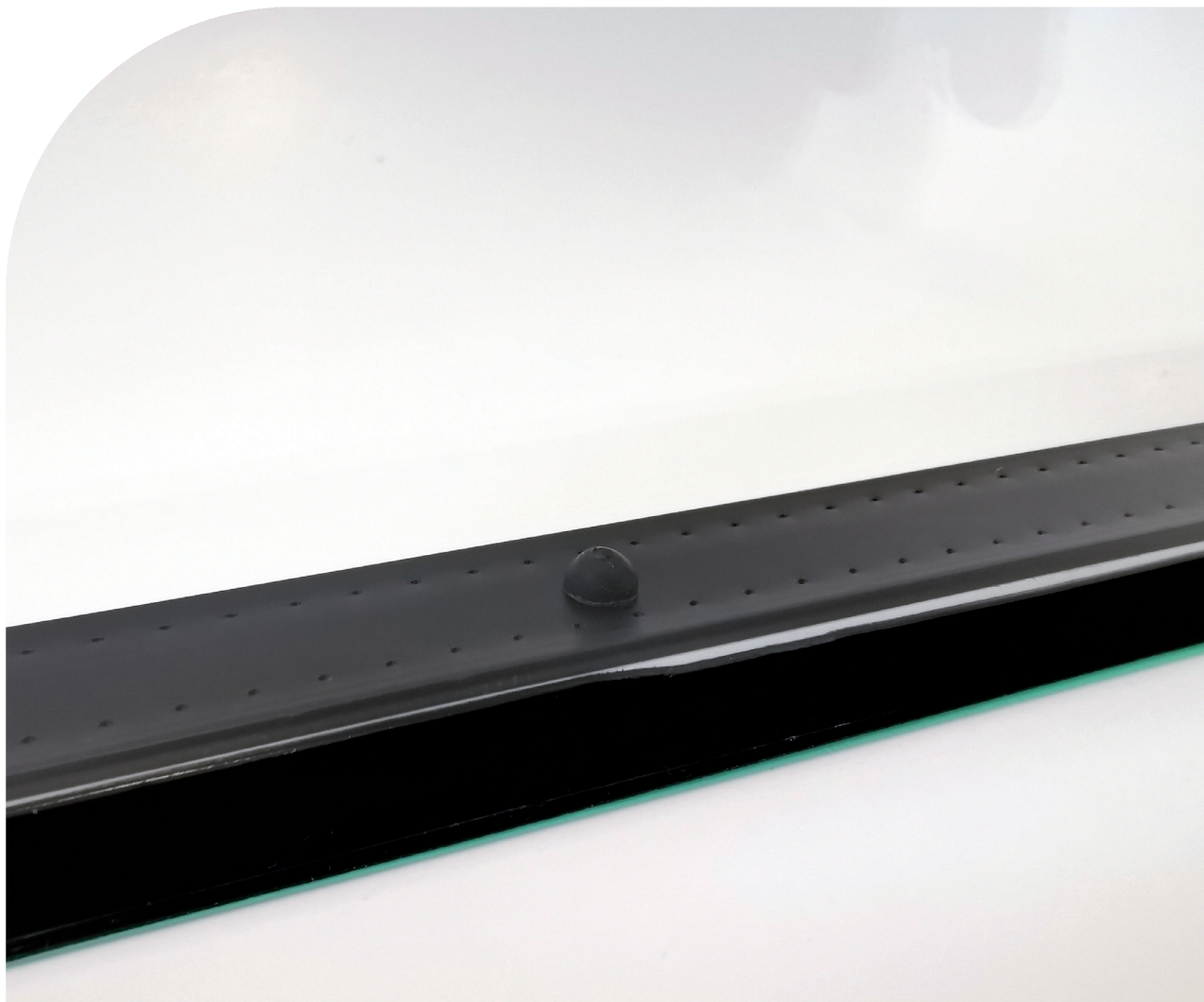
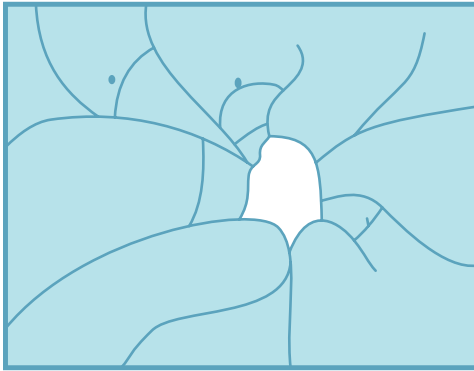

Fig. 14. Rubber plug in the spacer hole.

10.9 Toughened and heat strengthened glass

How the glass breaks depending on the type:

Annealed glass



Toughened glass

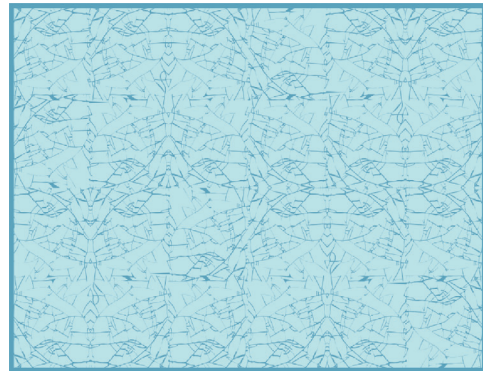

10.10 Glass deflection due to changes in temperature and atmospheric pressure

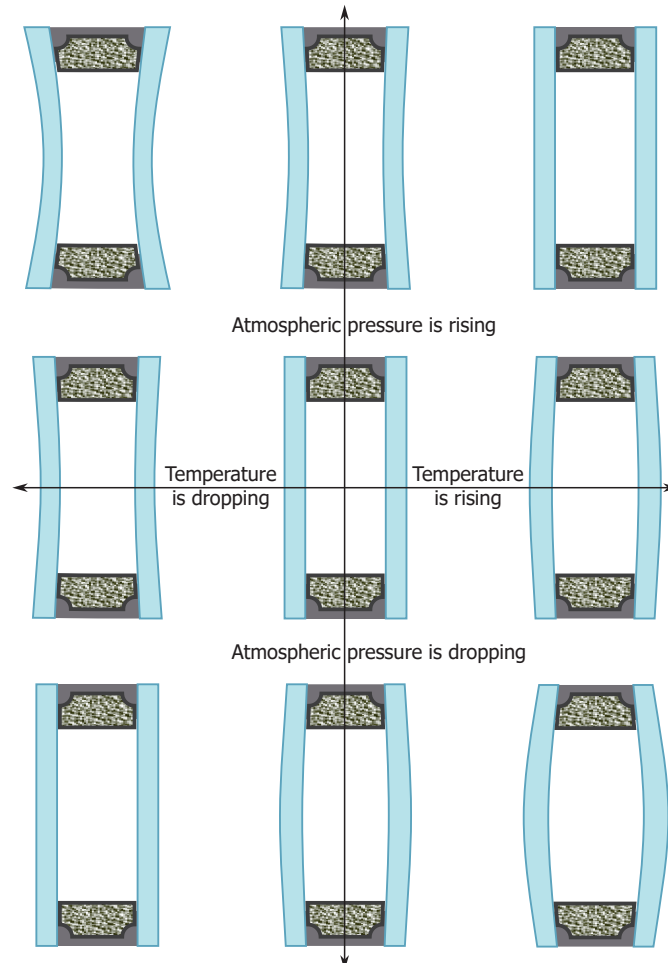

10.11 Thermal cracks

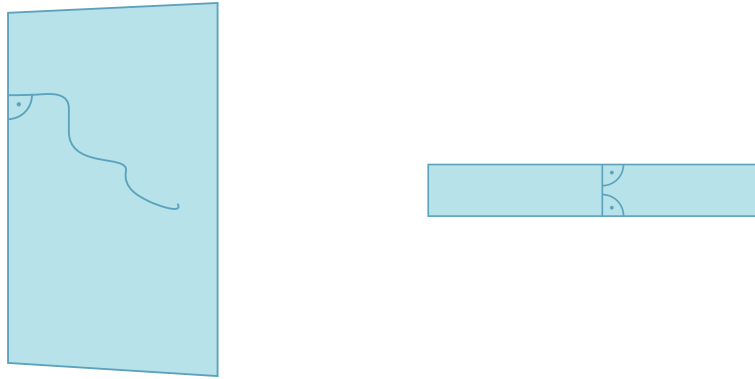

Fig. 15. Standard thermal crack

10.12 Mechanical cracks

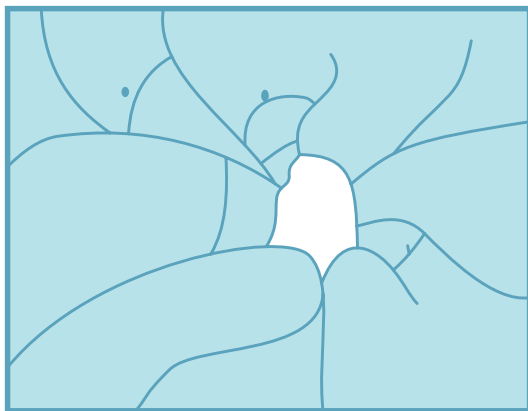

Fig. 16. Striking the glass surface, e.g. by throwing a stone.

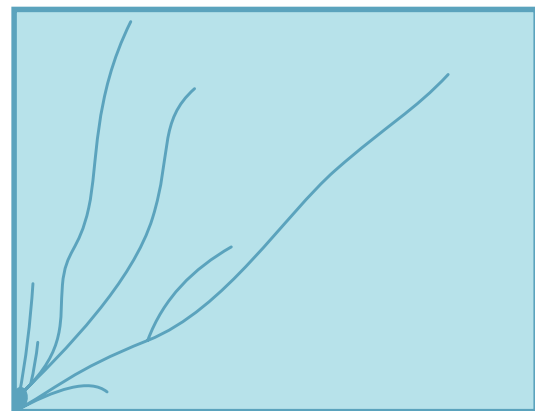

Fig. 17. Striking the corner.

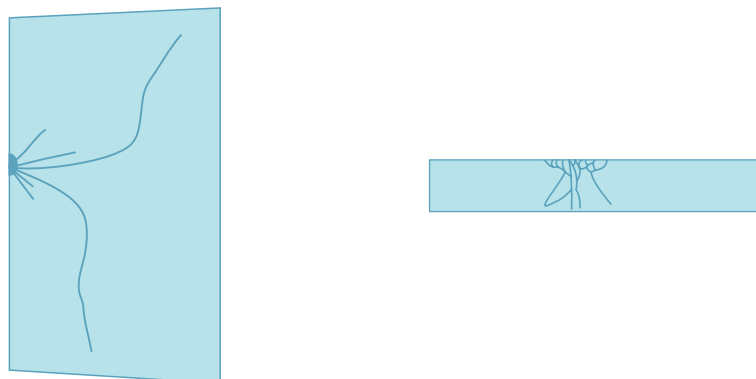

Fig. 18. Striking the edge (placing on a stone or piece of metal).

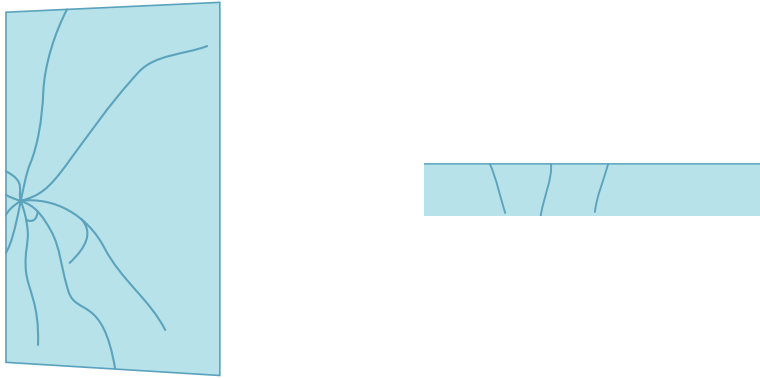

Fig. 19. Striking the edge (hitting the glass surface, e.g. hitting the pane strip with a hammer).

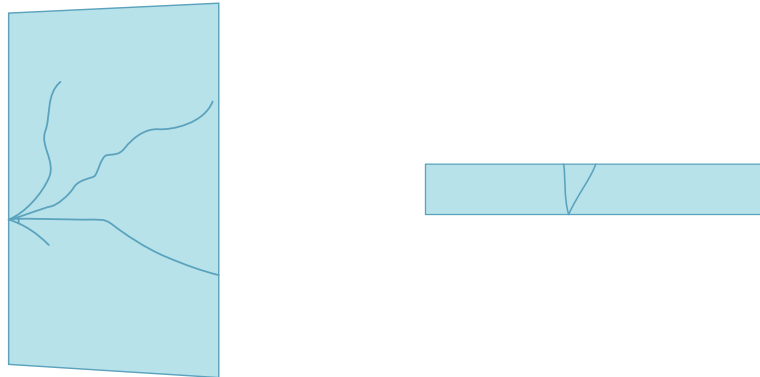

Fig. 20. Pressure on the edge (e.g. incorrect blocks for the glass weight).

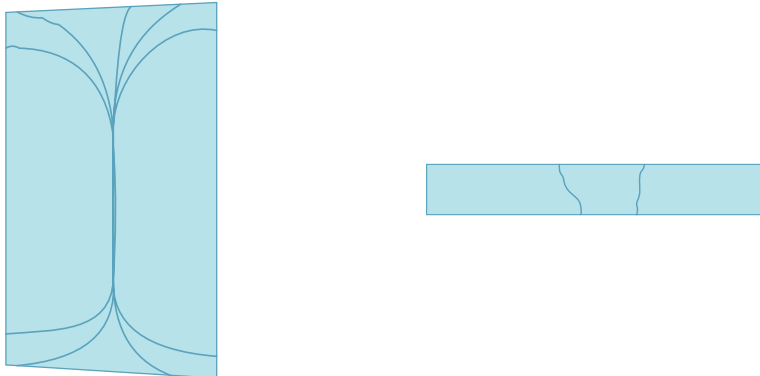

Fig. 21. Crack caused by surface pressure.

10.13 Standard size limits of IGUs, delivered by Pilkington IGP

Pilkington IGP Sp. z o.o., for the sake of customer satisfaction and to minimize the risks which may arise from not proper specification of size and structure of insulating glass to the most common wind loads, presents the following recommendations in this regard.

Communicated below maximum, recommended sizes limits of IGU should not be deemed as a maximum sizes of IGU available in Pilkington IGP.

Recommended sizes limits should be understood as the warning thresholds, in the case of their exceeding, it is advisable to analyze the construction of insulating glass unit for adaptation to existing loads and environmental conditions.

Glass thickness [mm]	Spacer bar [mm]	Maximum length of IGU [mm]	Maximum width of IGU [mm]	Maximum area of IGU [m ²]	Maximum side of square [mm]
3	6 - 16	1500	1270	1,60	1270
4	6	2420	1300	2,86	1300
	8-10	2440	1300	3,17	1300
	12-20	2440	1300	3,17	1300
5	6	3000	1750	4,00	1750
	8-10	3000	1750	4,80	2100
	12-20	3000	1815	5,10	2100
6	6	3500	1980	5,88	2000
	8-10	3500	2280	7,98	2440
	12-20	3500	2440	8,54	2440
8, 10	6	3500	2000	7,00	2440
	8-10	3500	2500	8,75	2700
	12-20	3500	2500	8,75	2700
12	12-20	3500	2700	9,45	2700

Table 27. Standard dimensional limits for insulating glass units.

Comments:

1. The above standard sizes limits refers to translucent IGUs, installed vertically, in places where there are no increased burden on the wind.
2. The limits do not take into account the impact of heat-reflecting coating on the rise the temperature inside the glass and the effect of changes in air pressure resulting from an installation in mountain areas.
3. The Limits do not include specific customers requirements regarding safety, wind loads, etc.
4. If IGU structure is with various glass thicknesses, the maximum surface area is determined in respect of the thinner glass.
5. To determine the maximum dimensions of the laminated glass, thickness of laminated glass should be multiplied by a coefficient of 0.63. This means that the type of glass 33.1 is equivalent to 4 mm float, 44.1 - 44.4 corresponds to the glass 6 mm float.
6. These limits do not apply to toughened glass.
7. In the case of glass thicker as in table above, dimensional limits are linked to the technical capabilities of the IGU manufacturing lines.
8. Cases of IGUs with a size exceeding the limits should be consulted with technical advisors.

11. Permissible tolerances of dimensions and thickness of insulating glass units

Parameter	Acceptable tolerance
Dimensions	+2,0/-1,0 mm
Thickness	± 1.0 mm (annealed glass) ± 1.5 mm (toughened glass, laminated glass, patterned glass)
Diagonal difference	< 2 mm/m
Pane's displacement	< 2,0 mm

Table 28. Permissible tolerances of dimensions and thickness of insulating glass units.

12. Fire protection glass

Requirements – Classification (according to EN 13501-2)

Pilkington IGP offers product types for various degrees of protection required by fire regulations:

- EI... Pilkington **Pyrostop**® – Full fire insulation (integrity + insulation).
- EW... Pilkington **Pyrodur**® – Increased fire integrity (integrity + reduced heat radiation).
- E... Pilkington **Pyroclear**® – Basic fire integrity (barrier against smoke, flames and gases).

Pilkington **Pyrostop**® – selection of full fire insulation

Pilkington **Pyrostop**® is a colourless fire-protection glass that can be used in various applications. Pilkington **Pyrostop**® provides full fire insulation and ensures the basic parameters of fire integrity (creating a barrier against flames, hot gases and smoke), effectively blocking heat transfer to the protected, safe side of the fire partition. Excellent results during repeated fire tests of Pilkington **Pyrostop**® and its behaviour observed during real fires is a confirmation that our company has expertise and the ability to produce durable multilayer laminated glass that swell under fire conditions. In glass of this type, individual float glass panes are joined together with an exceptionally transparent, protective fire-resistant gel. In the event of a fire, the pane on the fire side breaks due to the swelling of the first gel layer. The swelling gel hardens and becomes opaque, blocking the fire and absorbing its energy. The process is gradual, layer by layer in Pilkington **Pyrostop**® and Pilkington **Pyrodur**®, ensuring long-term fire resistance of the partitions and stability in the conditions of intense fire. The glass remains a tight barrier, the heat is effectively blocked, and the high resistance to flames and smoke is maintained throughout the duration of the fire exposure.

Pilkington **Pyrodur**® – selection of fire integrity with limited heat radiation

Pilkington **Pyrodur**® is a colourless fire-resistant glass designed to meet the criteria of increased fire integrity understood as a barrier to flames, hot gases and smoke, but also to limit the penetration of thermal radiation. It is based on the same technology as Pilkington **Pyrostop**®. In addition to the basic fire integrity, Pilkington **Pyrodur**® significantly reduce the transmission of thermal radiation and can even provide a minimum level of fire insulation (for a standard test time of 15 minutes). Pilkington **Pyrodur**® is a glass with increased fire integrity, ideal for use in doors and fire barriers leading to emergency exits, where fire integrity is required as the minimum level of protection.

Pilkington **Pyroclear**® – selection of basic fire integrity

Specially designed edge processing technology and a special procedure of the glass toughening process make Pilkington **Pyroclear**® reliable and durable protection in the event of fire. It is intended for use as a smoke barrier ensuring basic fire integrity in places where limited fire pressure is expected. The high performance in fire tests, especially when the glass edges are recessed up to 15 mm in the frames, is unique and makes Pilkington **Pyroclear**® a practical and convenient choice for various applications.

The hallmark of Pilkington **Pyroclear**® is the increased reliability achieved by focussing on the technical details, processing quality and awareness of risks associated with fire, based on over 30 years of experience in working on colourless fireproof glass. Pilkington **Pyroclear**® is the obvious choice for cost-effective glass providing basic fire integrity.

12.1 Offered products

Fire resistance classification	Glass type name	Mono	IGU	
E30	6 mm Pilkington Pyroclear [®] 30-001	1400 x 3000	1400 x 3000	Dimensions higher than those given in the table to be agreed with the Fire Protection Glass Sales Manager
E30	8 mm Pilkington Pyroclear [®] 30-002	1600 x 3000	1600 x 3000	
E30	10 mm Pilkington Pyroclear [®] 30-003	1800 x 3500	1800 x 3500	
E60	8 mm Pilkington Pyroclear [®] 60-002	1200 x 2830	-	
E/EW 30	7 mm Pilkington Pyroclear [®] 30-10	1200 x 2300	-	
E/EW 30	9 mm Pilkington Pyroclear [®] 30-103	1200 x 2600	-	
E/EW 30	11 mm Pilkington Pyroclear [®] 30-203	1590 x 3000	1590 x 3000 1680 x 3000 - TGU	
E/EW 60	10 mm Pilkington Pyroclear [®] 60-10	1300 x 1800, 1200 x 2000	1300 x 1800, 1200 x 2000	
E/EW 60	13 mm Pilkington Pyroclear [®] 60-20	1300 x 1800, 1200 x 2000	1300 x 1800, 1200 x 2000	
E/EW 30	14 mm Pilkington Pyroclear [®] 30-200	1500 x 3000	1500 x 3000	
E/EW 60	19 mm Pilkington Pyroclear [®] 60-202	1400 x 2800	1400 x 2800	
EI30	15 mm Pilkington Pyroclear [®] 30-10	1800 x 3000	1800 x 3000	
EI30	18 mm Pilkington Pyroclear [®] 30-20	1800 x 3000	1800 x 3000	
EI30	44 mm Pilkington Pyroclear [®] 30-401	-	1050 x 2000	
EI45	19 mm Pilkington Pyroclear [®] 45-200	1500 x 3000	1500 x 3000	
EI60	23 mm Pilkington Pyroclear [®] 60-101	1500 x 2850, 1430 x 3000	1500 x 2850, 1430 x 3000	
EI60	27 mm Pilkington Pyroclear [®] 60-201	1500 x 2850, 1430 x 3000	1500 x 2850, 1430 x 3000	
EI60	56 mm Pilkington Pyroclear [®] 60-401	-	1050 x 2000	
EI90	37 mm Pilkington Pyroclear [®] 90-102	1980 x 2850, 1890 x 3000	1980 x 2850, 1890 x 3000	
EI90	40 mm Pilkington Pyroclear [®] 90-201	1980 x 2850, 1890 x 3000	1980 x 2850, 1890 x 3000	
EI120	58 mm Pilkington Pyroclear [®] 120-10	1400 x 2600	-	

Table 29. Products offered by Pilkington IGP.

12.2 Fire-resistant glass codes

23 mm Pilkington **Pyrostop**[®] 60-101

1. number

60 Time of fire resistance or thermal insulation in minutes

1. digit of 2. number

0 Internal/external application (relevant only for Pilkington **Pyroclear**[®])

1 Internal application

2 External application without coating

3 External application with coating

4 External application with coating for horizontal or sloped installation (Insulating glass unit)

5 Internal application for horizontal or sloped installation

2. digit of 2. number

0 Monolithic glass

2 Monolithic glass in combination with texture glass

5 Insulating glass unit in combination with float glass as outer pane

6 Insulating glass unit in combination with toughened safety glass as outer pane

7 Insulating glass unit in combination with acoustic laminated safety glass as outer pane

8 Insulating glass unit in combination with laminated safety glass as outer pane

3. digit of 2. number

0, 1... Index number of different product compositions (not relevant for some product compositions).

12.3 Guidelines for transport, assembly and storage of fire-resistant glass units

All fire-resistant glass units must be stored in dry condition. They must not be exposed to rain, moisture, direct sunlight or other heat sources. This also applies to the storage of glass units on stands or in wooden crates.

Glass units can only be stored in an upright position, with a deviation from the vertical not greater than 6°. Mass of the glass units should rest on two rigid supports, but avoid direct contact between the glass and any metal components.

During storage and installation of the glass units in window openings, the fire-resistant units must be supported in such a way that a 90° angle is maintained between the units' surface and the plane of support of the bottom edges of the units. This position will prevent misplacement of glass panes in the fire-resistant glass units and damage to the glass.

Pads and components securing the glass against tipping over must not damage the glass units or the tape covering the edges of the units. Make sure that individual glass units are separated by cork pads.

Before starting the installation, each insulating glass unit should be inspected in detail, paying particular attention to possible cracks, scratches and damage of the tape covering the edges of the glass (cuts, tear, peeling).

Glass units with such defects must be immediately returned as nonconformant since once they are installed, quality complaints will not be accepted.

Attempts to tear off or remove the tape protecting the edges of the units are unacceptable as it may lead to irreversible loss of the units' integrity.

When rotating, reloading or assembling the units it is unacceptable to rest the glass units on one of the corners.

Each Pilkington IGP fire-resistant glass unit has a special sticker that briefly summarises the above recommendations.

Fig. 22. Sticker on fire-resistant glass units.

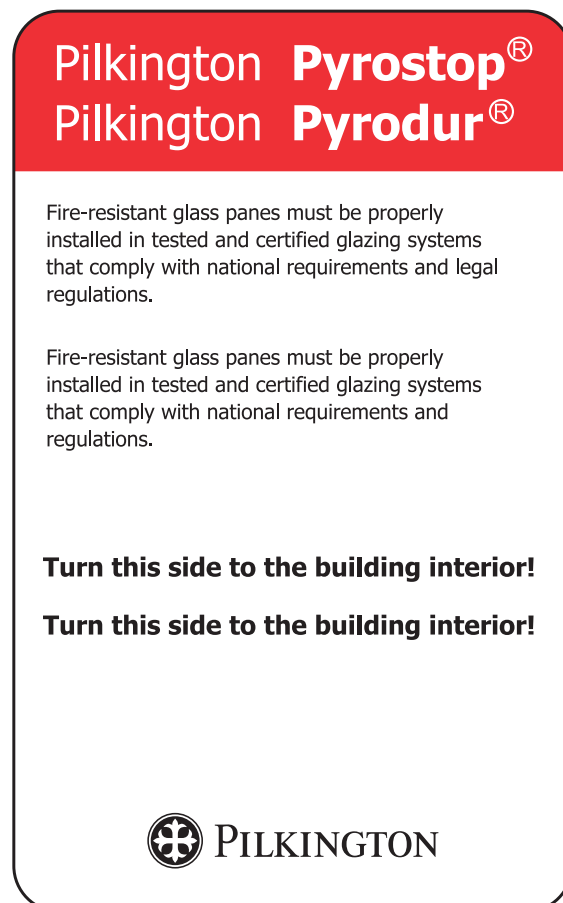
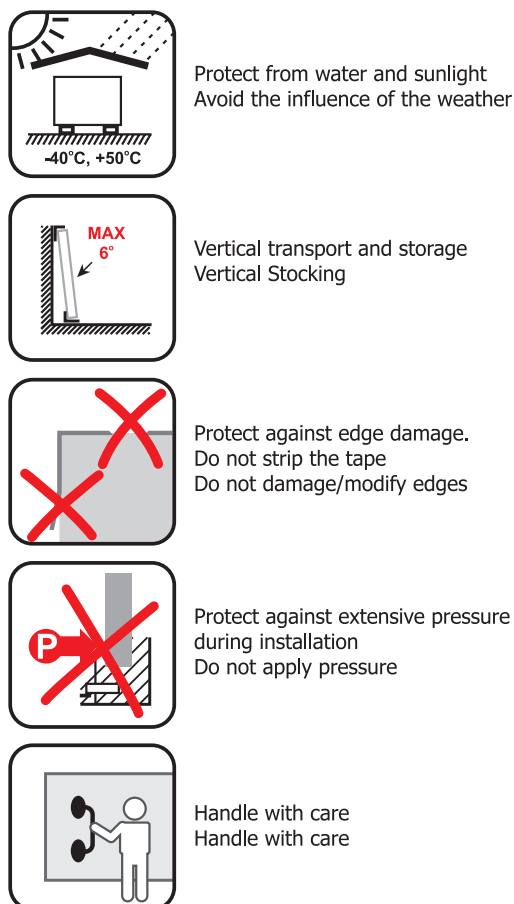

12.4 Pilkington Pyrostop® or Pilkington Pyrodur® glass units installation.

The basic element that requires attention during the installation of glass units is the correct recognition of which side of the unit should face the building.

The glass units should be installed in such a way that the above sticker is directed to the inside of the building!

If a glass unit intended for installation on an exterior wall does not have the sticker, stop installation and contact Pilkington IGP for clarification and to avoid incorrect installation of the glass unit.

Installing the units back to front leads to irreversible defects of the unit after some time.

During the installation, it is necessary to ensure even pressure on the edges of the glass units. The pressure exerted on the edge of the units should not exceed 20 N/cm around the perimeter of the unit.

13. Washing and cleaning of glass supplied by Pilkington IGP

Use clean water mixed with cleaning agents and ordinary soft cloths or sponges to clean the glass.

Using alkaline or fluorine-containing cleaning agents is forbidden. Grease and sealing material residues should be removed with commercially available non-aggressive solvents (alcohol, isopropanol), then rinsed thoroughly with water.

Cleaning of spot stains with abrasive products, i.e. scouring powders or materials that cause scratching (fine steel wool, razor blade flat against glass, etc.) must be done carefully to avoid scratching the glass surface. Do not use such tools to clean ("scratch") the entire surface of the glass.

Washing of glass

- a) Wash the glass with water and commercially available glass washing products.
- b) Rinse with plenty of water before and after cleaning with chemical products. Avoid rubbing the glass surface on which fine debris from sand, dust, rendering mortar, etc. has accumulated. First, remove all debris with a strong jet of water and wipe the glass dry. Do not clean the glass with any metallic or ceramic scrapers or scourers to remove dirt. Do not use any pastes or solutions containing any abrasive grit which might scratch the glass surface.
- c) Dirt which cannot be removed with the methods specified in Point (b) can be cleaned with soft-bristled brushes, rubber, leather or fine steel wool without any abrasive grit. Perform a test first to make sure the tools do not damage the glass.
- d) Stains from paint, tar, etc. can be removed with ethanol, isopropyl alcohol, acetone or gasoline. After using the above-mentioned measures, the surface of the glass should be washed with water and wiped dry. However, care should be taken to prevent the liquids from coming into contact with other elements, e.g. varnish covering aluminium structures.
- e) Do not wash the glass with solutions of acids or alkalis, especially liquid acids or cleaners based on fluoride or chloride – these chemicals can irreversibly damage the glass surface.
- f) Wash the glass regularly with a frequency which depends on how heavily soiled the glass is. Note that if not removed, all types of dirt, stains, and tarnish will become increasingly harder to remove over time, increasing the risk of damage to the glass during cleaning.

13.1 Washing and handling of self-cleaning glass

Pilkington **Activ**[™] is a durable, coated self-cleaning glass with a neutral colour that may be washed less often compared to standard glass, and provides better visibility during and after rainfall. Pilkington **Activ**[™] is durable and scratch-resistant and can generally be handled in the same way as standard float glass.

Under normal conditions, the unique coating breaks down organic dirt and enhances the effect of a thin water film on the coated surface.

This allows dirt to be easily washed off the surface, which significantly reduces the need to wash the glass manually.

Pilkington **Activ**[™] can be used as single glazing or as insulating glass units with a self-cleaning coating directed to the outside of the building. Pilkington **Activ**[™] must be installed in accordance with Pilkington IGP's recommendations. This will make the most of its unique self-cleaning properties and will not damage the valuable coating.

Transport and storage. The glass is coated, therefore care should be taken during unloading and storing to avoid surface damage.

Detecting the presence of the coating. The Pilkington **Activ**[™] coating can be identified by placing a detector to the coating, which is available from your nearest Pilkington IGP representative.

Handling of glass. The coating is hard and difficult to damage, so no special precautions are needed. Suction cups may be used on the coated surface, but they must be clean, dry, non-slip and in good condition. Wear clean cotton or cloth gloves when handling the glass by hand. If the glass requires some form of identification, it should be marked on the uncoated side. Do not use stickers or wax crayons on the coated surface as they may be difficult to remove.

Glazing rules

Dry-sealed glazing systems or systems using non-curing, oil-free components should be used whenever possible. The seal should be of high quality, which will minimise the process of washing the silicone off its surface. Silicone sealants may release oils or silicone-containing plasticisers both during the process of curing and long afterwards. Such substances are very difficult to remove from the glass surface and coating surface.

They are usually only visible on wet glass/coating and even then they can only be seen by a different pattern of water droplets than the pattern visible on clean glass surface. Avoid using silicone lubricants on the seals. When mounting glass units in window frames, glass tapes containing oils (e.g. silicone and/or paraffin wax) should not be used. Pilkington **Activ**[™] coating should, however, over time decompose some of the oils and greases.

Caution: Do not use linseed oil putty for Pilkington **Activ**[™] glazing. Before selecting seals, please see the latest glazing technical instructions available on request.

Insulating glass units with Pilkington **Activ**[™] coating are marked with a Pilkington **Activ**[™] sticker. After installing the glass, the sticker must be removed. In places where the glass is adjacent to fresh lead joints (in greenhouses for example), white lead carbonate may stain Pilkington **Activ**[™] like any other float glass. This can be prevented by applying a patination compound or Leadshield[™] to the metal joint surface while it is still fresh.

Due to possible reactions with sea salt, the use of Pilkington **Activ**[™] glass is not recommended in the immediate vicinity of a sea. Similar to other types of glass, check that there are no alkaline leaks from adjacent concrete, etc.

It is the responsibility of the contractor to ensure that the above recommendations are followed during assembly. Once the Pilkington **Activ**[™] glass is installed, be careful not to stain or damage the coating during the execution of any later works. The coating should be protected against contamination and damage caused by welding, rust, cement, plaster or glue deposits. After completion of works, the glass should be washed as soon as possible by rinsing them with water to remove traces of dust, abrasive materials, etc. that accumulated during construction. Then, a cleaning agent should be sprayed or applied with a wet cloth on the coated surface (a mild solution of detergent and water is recommended). Once the coated surface is wetted, it should be gently washed with a smooth, clean cloth.

Washing

Pilkington **Activ**[™] has a hard, durable coating applied to the surface of glass in the float glass production process. As with any coated glass product, care should be taken while washing the glass to prevent damage to the coating. The coated surface must not come into contact with metal, e.g. metal cleaning equipment components. For machine washing, hand washing and removing of stains from Pilkington **Activ**[™] glass, please follow the instructions given below.

Hand washing / stain removing

Pilkington **Activ**[™] glass can be washed by hand. It is recommended to use a mild, non-abrasive solution of detergent and water that is free of solids. Do not use abrasive cleaners. When washing/cleaning the coating, apply the solution to the glass with a clean, soft cloth or sponge, and then rinse the solution with clean water. The glass surface should be dried with a soft, lint-free cloth. When wiping the coating, make sure there are no abrasive particles between the glass and the cloth that could damage the coating.

Commercial window cleaners containing ammonia or alcohol can be used to remove stains, but using steel wool or razor blades is forbidden. When washing the coated glass surface, it is not recommended to use rubber squeegees to remove water from the panes. If using the squeegee is necessary, make sure that metal parts of the squeegee do not touch the coating.

The squeegee also must not soil the glass as it may scratch the surface while washing.

Caution: Acceptable silicones, lubricants, seals, etc.:

<https://www.pilkington.com/en/global/products/product-categories/self-cleaning/pilkington-activ-range#technicalupdate>

13.2 Washing glass at the construction site

Cleaning water as well as cloths or sponges must be free from sand and other foreign bodies. Cement dust or other abrasive residues must not be removed dry!

If the glass is heavily soiled, use more water for washing accordingly.

Water contaminated with fresh concrete is corrosive, therefore it must be kept away from the glass surface. Traces of cement sludge and remnants of building materials should also be removed from the glass immediately. Leaving such deposits on the glass for a longer time may cause permanent damage to the glass surface (matting).

14. Construction site proceedings

Heaters, heat radiators or blowers must not act directly on fire-resistant glass. Heaters located in the vicinity of glass should have covers, and the distance from the glass should not be less than 30 cm.

Pouring asphalt indoors causes a high thermal load so fire-resistant glass must be protected. For this reason, we generally recommend to install glass after pouring the asphalt. If this is not possible, insulating glass units should be protected against thermal radiation by means of a suitable covering of the entire surface. If solar radiation may additionally increase the temperature, the covering is also necessary on the outside. It refers especially to coated glass.

Grinding/welding works in the close vicinity of windows require effective and direct protection of the glass surface against welding spatter, sparks, etc.

Pitting and damage on the glass surface may be caused by chemicals contained in building materials and cleaning agents, e.g. liquid glass additives. Such chemicals cause pitting, especially when they are left on the glass for an extended period of time.

As the reasons may vary, it is not possible to define any universal precautionary measures. They should be defined and implemented based on the conditions existing in a specific situation.

Shading and heat accumulation, which may occur as a result of atypical installation conditions, e.g. in niches, with blinds, awnings, but also close to radiators, etc., if the conditions are not taken into account, may cause glass cracking due to the temperature difference. Also painting, sticking foil or applying other materials in locations where extensive solar radiation occurs may cause thermal overload of the glass and the fireproof layers between the glass panes.

The same applies to all outdoor fire protection tightly fitted glazing units that are inadequately ventilated, as a cladding or laminate installed on building elements (e.g. to cover an opaque strip or roof cornice).

15. Packing of glass

Glass should be handled and transported in dedicated packaging units such as steel transport racks, wooden crates, or suitably constructed wooden racks. The packaging method must comply with the requirements for glass safety in transport and provide protection of the glass from damage. Trucks with air suspension system and closed bodies should be used for glass transportation.

The glass racks should be loaded along the vehicle's centreline and a secure spacing must be kept between the racks and the glass. The lashing of the glass to the racks and of racks to the truck structure should eliminate any risk of displacement in transit, even in hard braking conditions. The truck body must protect the cargo against direct sunlight, rain and ingress of fine hard debris, such as sand grit, which can damage the glass surface.

The glass should be loaded on the rack for transport exactly the same way as for storage. The lashing pressure during transport should be increased to prevent the glass displacement.

Insulating glass units are usually packed on returnable metal racks with individual units separated with cork spacers. Depending on the customer requirements, as well as the distance and method of transport, we also use individual packaging methods, including non-returnable wooden and metal packaging (crates, stands). In such situations, the method of packing is agreed individually at the stage of quoting.

15.1 Packing - metal racks

Pilkington IGP is a manufacturer of metal stands. They are made in accordance with applicable standards, including PN-EN ISO 12100:2012P and PKN-CEN 414:2006.

We use four basic types of steel racks: GIGA, AX, A and L (optional L "FRIGO"). Each type is available in various sizes.

Steel components of the racks that are in contact with the glass are protected with rubber pads.



Fig. 23. L-type metal rack, stacked.



Fig. 24. MEGA/GIGA type metal rack.



Fig. 25. L-type metal rack, stacked.



Fig. 26. Type A metal rack.

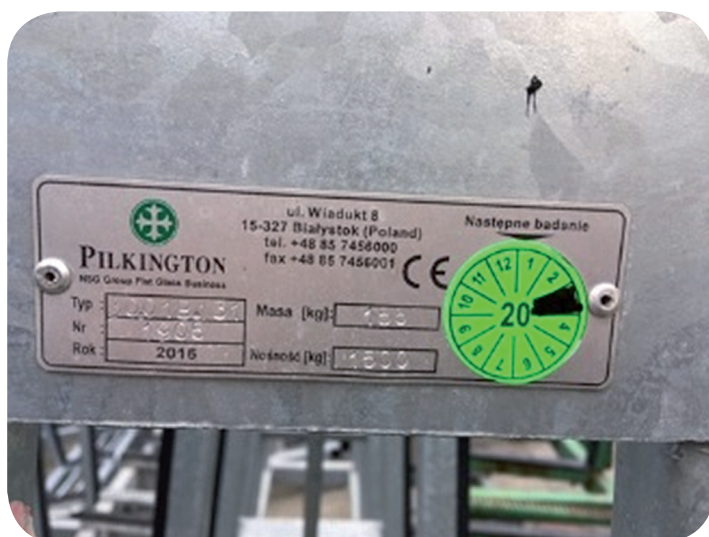

Each rack has a nameplate and a unique barcode with an identification number.



15.2 Packing - wooden packages

Upon the client's request, we also use A-type and L-type wooden racks and wooden crates of various sizes.

Fig. 27. L-type wooden rack.



Fig. 28. Wooden crate.



Wooden parts of the racks that are in contact with the glass are protected with foam pads.

All wooden racks have an identification number and are properly marked.



Fig. 29. Marking of wooden racks.

15.3 Positioning and securing glass on the racks

The basic rule is to put the glass along the long edge of the sheet. Standard order of putting glass on the rack is from the highest one to the lowest one and is aimed at safe and optimal packing of the glass. Special packing order, e.g. in an order requested by the client, is possible if appropriate arrangements are made before placing the order.

Depending on the client's requirements and the type and size of the glass, apart from the cork pads, other materials (e.g. rubber, cardboard, polystyrene, etc.) can also be used to separate glass on the rack.

Glass on the rack is secured against displacement by means of an appropriate amount of polypropylene tape.

The arrangement and number of components securing the glass during transport varies depending on the number, size and type of glass.

Fig.30. Example methods of packing and securing glass on racks.



Depending on the needs, racks filled with glass can also be wrapped with transparent or milky plastic sheet in order to protect them against rain or snow for transportation. It should be noted, however, that in accordance with the recommendations by Pilkington IGP Sp. z o.o., glass must be transported by closed tracks only, and the glass must be stored in places protected from rain and direct sunlight. All temporary protection against precipitation (plastic wrapping around the rack, tarpaulins, etc.) should be removed during storage.



Fig. 31. Example methods of packing and securing glass on racks.

15.4 Unloading

Wooden and metal racks and crates should be unloaded with forklifts. Metal racks are also suitable for unloading with a crane equipped with a suitable sling. Before unloading, please read the information given on the rating plate of the rack and the marking on the racks and wooden crates.

Before unloading, check the condition of the glass protection on the rack.

Any damage to the cargo should be recorded in the shipping documents and properly described (e.g. photos).

15.5 Shipping documents and receipt of goods

Along with the delivery, the customer receives a set of shipping documents:

- racks hand-over report,
- delivery report,
- CMR, if shipped abroad.

Before starting to unload, read the documents. Once the truck is unloaded, sign off in the appropriate boxes and make notes about any damage or missing quantities if identified.

16. Annex 1: Standard warranty general conditions for insulating glass units

1. In accordance with the terms below, Pilkington IGP Sp z o.o. ("Pilkington") provides a warranty for Pilkington **Insulight™** glass units manufactured by Pilkington. The warranty is either provided:
 - as part of an offer submitted by Pilkington and accepted, in a form defined by Pilkington by the Buyer, being then the basis for a sales contract, or
 - as an agreed commitment in a sales contract.
 2. The Warranty covers only Pilkington **Insulight™** glass units manufactured by Pilkington, designed for building and construction works, marked on the spacer with the Pilkington Insulight brand name, symbol of the specific Pilkington manufacturing plant, and date of production.
 3. The scope of this Warranty covers only risk of loss of glass unit tightness, and the tightness is understood as a lack of water vapour condensation (at normal atmospheric conditions) inside the glass unit (on the internal surfaces of glass panes).
 4. The Warranty covers only the cases where the tightness was lost due to material or workmanship defects of the delivered glass units, if the defects can be attributed to Pilkington.
 5. The Warranty does not cover the glass units for which the loss of tightness occurs simultaneously with cracking or breaking or mechanical damage of at least one of the glass panes included in the glass unit.
 6. The Warranty period is assumed to begin on the date of manufacture of the glass unit, as marked on the glass unit spacer.
 7. For any claim to be valid under this warranty, the glass unit defects must be notified by the Buyer to Pilkington in writing not later than within 30 days from the date of defect.
 8. The Warranty is provided for a period of:
 - 5 years for rectangular glass units
 - 2 years for non-rectangular glass units
 9. The Warranty is provided under the condition that the Buyer shall observe general rules (according to glass handling practices) of storage, transport, installation, use and maintenance of the glass units, or other specific Pilkington guidelines provided to the Buyer directly and/or made generally available on the Web site: www.pilkington.pl.
- Pilkington shall not be responsible for defects occurring in the products supplied by Pilkington which are caused by lack of observance of the above mentioned rules and guidelines by the Buyer.
10. This Warranty does not cover the following products:
 - curved glass units,
 - custom products, non-conforming to the "Performance Standards of Glass Products Manufactured by Pilkington IGP",
 - glass units, for which the structure was specified by the Buyer and turned out to be improper considering the shipment handling and conditions, storage, installation, and/or use,
 - products made according to the Buyer's request and on their risk, despite the Pilkington standards and guidelines.
 11. The Warranty is provided on the condition that Pilkington, acting through an authorised person, is able to check each product for which a complaint is submitted in accordance with the rules of this Warranty, including how the product was installed and used. The Buyer is obliged to provide Pilkington representatives with an opportunity to properly examine the product for which the complaint was made.
 12. In the case of a justified complaint, Pilkington's liability under this Warranty is limited to supplying a replacement product, free from defects, to the Buyer's site, or the site indicated by the Buyer, at the surrounding ground level, or to return the price of the faulty product – at the discretion of Pilkington. All other liabilities are excluded.
 13. Pilkington's liability under this Warranty is limited to the products used in building and construction works.
 14. All other issues not covered by this Warranty are governed by the Pilkington "Sales Conditions".

Sandomierz, Poland, 22th of February 2014

Approved by:

Krzysztof Granicki

President of the Pilkington IGP Sp. z o.o.

17. Annex 2: Pilkington IGP processed glass manufacturing standards

Item	Critical feature	Standard arrangements	Deviations from Standards which must be communicated to Pilkington IGP upon request for proposal and/or product purchase.
1.	Intended use of product	To be used in civil engineering and construction works	In other applications, e.g. in lift glazing, furniture, ship's windows, automotive, household appliances, it may be necessary to satisfy other or additional requirements for the product (e.g. marking, quality, certificates).
2.	Use venue	Depending on design, intended use and size of insulating glass units (IGU), generally it is not recommended to install glass at the height of more than 650 m a.s.l., as for double glazed units - exceeding 400 m a.s.l may require consulting.	Use of IGUs at higher levels than manufacturing venue raises cracking or glass tightness loss risk - in such cases it is advisable to analyze correct choice of thickness and size of glass. Upon order, at glass manufacturing stage, it is possible to adapt internal pressure of glass unit to anticipated final location.
3.	Type of transport	Road transport up to 1000 m a.s.l.; transport by sea or air - not recommended.	If IGUs are to be transported by air or sea, it is necessary to consult it with Pilkington IGP beforehand.
4.	Glass unit position when in use	Vertical - as fixed, tilt or turn window.	Sloping position (roof skylights, canopies, winter gardens, glass ceilings) usually requires customized adaptation of glass designs to loads and requirements related to safety of use.
5.	Elements raising glass cracking risk when using, or reducing glass durability	When using, there should be no elements limiting free flow of heat through glass units directly on glass units or near them. It applies particularly to IGUs based on annealed glass or laminates.	Presence of elements which permanently diversify flow of heat through glass, e.g. blinds, stick-on foils, glass decoration, suspended ceilings, furniture and structural elements covering part of glass - it may entail a need to use of toughened glass or heat-strengthened glass.
6.	Glass unit fixing method	All edges mechanically fixed along the whole length, coverage of edges of IGUs with external strip at the depth of 12-30 mm.	Other fixing methods (two-edge, spot-like, structural gluing, glass corners, fixing with glazing bar not more than 30 mm deep) - require use of silicone in IGUs, endurance calculations, selection of glass units on a case-by-case basis.
7.	Design of IGUs	External pane: clear glass, body tinted glass, with Pilkington Activ TM coating in position #1, with with solar control or low-e coatings in position #2; laminated glass, toughened glass, toughened with HST, heat strengthened with solar control coating; patterned glass, fire-resistant glass. Internal pane: clear glass, with low-emissivity coating in position #3 or #5, laminated glass, toughened glass, toughened with HST, heat strengthened with coatings, patterned glass, fire-resistant. Middle pane (in triple glazed units): clear glass.	Use of other than listed types of glass for external panes, middle panes or internal panes – is a non-standard solution and requires consultation regarding suitable selection, also with regard to possibility and period of guarantee.
8.	Use of patterned glass in IGUs	It is advisable to use in position in which smooth side of the patterned glass is directed towards distance frame.	As for body tinted patterned (yellow, honeyed, brown), it is advisable to toughen them in order to eliminate cracking risk during use.
9.	Compatibility of sealing compounds for IGUs with silicone and assembly adhesives	Pilkington IGP provides clients with information on assembly adhesives and silicone tested for no reaction/compatibility/to sealing compounds used for production of IGUs.	Before starting assembly of IGUs in window frames or facade, the contractor must confirm at the IGUs supplier's compatibility of assembly adhesive and silicone which may directly react to IGU sealing compounds. See also „Instructions on transporting, storing, assembling, using and maintaining glass items by Pilkington IGP Sp. z o.o.“
10.	Sealing compounds for IGUs	Butyl + polyurethane, polysulfide or other.	other is a two-component silicone – see point 6 non-standard fixing method.

Item	Critical feature	Standard arrangements	Deviations from Standards which must be communicated to Pilkington IGP upon request for proposal and/or product purchase.
11.	Product guarantee	By default Pilkington IGP Sp. z o.o. grants a guarantee for tightness of IGU for the period of 5 years for rectangular units or 2 years for non-rectangular units, on the terms specified in the „General terms of standard guarantee for IGUs“. We do not grant the guarantee for: float glass or glass with coating or without coating, patterned glass, toughened glass, enamelled glass, glass with screen printing, laminated glass, fire-resistant glass, because their declared performance should not deteriorate during use, except for features accompanying regular wear of glass product.	Granting longer guarantee for tightness of glass units or guarantee for glass units other than specified in „General terms of standard guarantee“ - requires arrangement before the order is placed. „General terms of standard guarantee for IGUs“ are available on www.pilkington.pl .
12.	Glass unit dimensions	See - „Standard size limits for IGUs of Pilkington IGP“ available on www.pilkington.pl . The size limits included in the Table are for reference only, the maximum sizes may be different - depending on specific design of glass units and their application. Production capabilities of Pilkington IGP allow production of larger glass units than specified in the size limits table. Pilkington IGP is not held responsible for correct adaptation of glass design and its size, thickness and type of glass to the place and conditions of use.	Manufacturing glass units whose parameters exceed values in size limits table, manufacturing IGUs and toughened glass with diameters below 250 x 350 mm or ratio bigger than 8:1 - requires arrangement before accepting the order.
13.	Nominal distance of distance frame from edge of IGU	Distance < 15 mm.	As for glass units for nonstandard applications (see p.6), thicker sealing compound/silicone may be required; simultaneously it may be necessary to move the distance frame farther from the edge of glass unit. In effect the transparent area of glass unit is reduced.
14.	Filling glass units with mix of gases	Argon or krypton – selection depending on required U coefficient; filling rate: 90 +10/-5 %.	Gas SF ₆ – not used. Mixtures Ar/Kr - upon special request of the client. Depending on shape and design, some IGUs are filled with gas through holes drilled in the distance frame. Sleeves and hole plugs may be visible for glass user.
15.	Type of spacer bars	The standard offer includes the following spacer bars: aluminum, galvanized steel, stainless steel, plastic or glass fiber combined with aluminum foil or steel foil. For rectangular glass units, the standard is to bend spacer bars in corners, assuring longer life and tightness of multiple glazed units.	Spacer bars are available in natural colours and colours provided by particular suppliers. The spacer bar's colour must be clearly specified in the client's order.
16.	Content of overprint on spacer bar	Pilkington IGP, unit number, manufacture date, order number and position	Depending on technical capabilities, upon the client's request, we may print additional information on distance frame.
17.	Quantity and location of connecting points of spacer bar	We do not guarantee existence of only one connecting points of spacer bar on the perimeter of the IGU. Additionally, connecting points of spacer bar may be located on various sides of the IGU	Special requirements regarding quantity or location of connecting points of spacer bar - require customized arrangements before the order is accepted.
18.	Colour of overprint on spacer bar	Black Note: legibility of overprint is dependent on colour of spacer and texture of its surface, in extreme cases it may require the use of strong source of light, UV lamp or disassembling the glass unit.	Blue, yellow or other colour after the client has approved the sample.

Item	Critical feature	Standard arrangements	Deviations from Standards which must be communicated to Pilkington IGP upon request for proposal and/or product purchase.
19.	Ground coatings in position #2 or #3 in double glazed units, or in position #2, #3, #4 or #5 in triple glazed units	Standard width of removing the coating (grinding) - 10 mm. By default the coating is removed along the perimeter of the glass in case of low-emissivity coatings and solar control; both in annealed and toughened versions and in laminates. on-line coatings are not ground, as per suppliers' recommendations	As for IGUs requiring thicker layer of sealing compounds (e.g. corner glass, structural glass, some kinds of single - and triple glazed units), the required coating grinding width may be higher than 10 mm.
20.	Decorative items inside the multiple glazed unit: mullions	Type, arrangement - as per client's drawing. In order to limit vibrations risk and mullions knocking, in decorative muntin linking points we stick minor transparent silicone disks (bumpons). In Vienna type mullions we use minor silicone ribbons, felt disks or plugs. For avoidance of frost penetration of glass unit with mullion, the minimum width of distance frame must be 12 mm.	If a single section of muntin is longer than 0,7 m, elements which dampen vibrations are stuck in half of its length. Glass units with mullions with Teflon veneer (e.g. „Renolit“ type) are manufactured without dampening pieces; glass units with these mullions are more exposed to unfavorable effects, such as vibrations, knocking of mullion. Generally speaking the width of distance frame must be higher than ca. 4 mm from mullion thickness.
21.	Blinds mounted in IGUs.	There is a wide range of blinds (colours, drive and control systems) mounted during production of IGU	Every time the order for IGU with blinds must be preceded by detailed arrangements covering the type of drive and control equipment.
22.	Same size of both panes in IGU (step present)	Both panes with identical size, no step.	Manufacturing IGUs in which one of glass panes is larger than the other (on one or several sides) - possible but requires detailed information at order placing stage. The standard is to manufacture such glass units with silicone sealing 6 mm thick.
23.	Appearance of step	As per intended use of glass unit and arrangement with client; step may be blackened with silicone or clear.	If the type of glass used requires grinding the coating on step, it is necessary to expect barely visible traces of grinding wheel on the surface. When the step blackens, this effect may get more visible.
24.	Marking of location of base edges of IGU, useful when assembling window opening	yes – on glass units in one size > 2,5 m a special sticker is placed near the edges based when integrating glass units.	The glass unit must be fixed in a way that one of based edges marked with sticker is the lower edge of glass in the window.
25.	Edge treatment method	By default – no edge treatment except for: • toughened glass, heat strengthened or heat-soaked glass is mechanically blunted on all edges, • some laminated glass laps have manually blunted edges for engineering reasons.	Pilkington IGP provides a wide range of other edge treatment methods (e.g. grinding, polishing, C-edge, etc.) and hole drilling, undercutting, cut-outs, cutting shapes with water-jet method - requires arrangement at order arrangement stage.
26.	Size tolerances	As per „Criteria for Quality Assessment of Glass Items by Pilkington IGP“ available on www.pilkington.pl and relevant product standards.	The above-stated quality requirements require case-by-case arrangement, before glass units are ordered.
27.	Flatness tolerances		
28.	Visual assessment, permissible flaws		
29.	Scope of glass testing and declared parameters	Each product is assigned the Performance Declaration to be downloaded from www.pilkington.pl . The declarations contain a full list of declared parameters.	Performing these tests, other way of declaring parameters or other scope of declared parameters - require arrangements at order arrangement stage.
30.	Intended use of toughened enamelled glass	Application as facade coating: single glass or combined with enamelled coating in position #2, #3 or #4; with nontransparent, balanced background located directly behind glass; no contact between coating and other materials.	Positioning of enamelled glass in the way allowing watching them in the transmitted light (partition walls, facade glazing) and application of enamel in position #1 - require case-by-case selection of manufacture method and approval of reference sample.

Item	Critical feature	Standard arrangements	Deviations from Standards which must be communicated to Pilkington IGP upon request for proposal and/or product purchase.
31.	Intended use of toughened glass with screen printing	Applications in spots in which glass is watched in the transmitted light and when it is necessary to mark a specific pattern on the glass.	Screen printing is made in accordance with client's unique pattern and on the basis of client's sample approval. As for patterns whose elements size is <3 mm, standard quality assessment criteria do not apply.
32.	Approval of colour of enamelled glass and with screen printing	Basic colours on clear float glass - see Pilkington IGP glass reference samples.	For other colours of coating and/or other types of glass used as surface - the client is expected to approve the reference sample.
33.	Toughening direction	No standard	Depending on glass size, it is possible to arrange the toughening direction as per glass height.
34.	Enameling direction	No standard	Under normal conditions we do not record any differences arising from application direction.
35.	Additional heat soak test (HST) for toughened glass	The standard is to provide this service for all toughened glass. Whether HST test is conducted depends on client's order	HST test is recommended to minimize theoretically possible spontaneous cracking of toughened glass arising from inclusion of nickel sulphide in molten glass.
36.	Way of preparing drawings, description of design of glass ordered	View from the outside of the building – applies to glass drawings, description of glass design.	
37.	Position of label on glass unit	Main sticker + side sticker with bar code. Location of main sticker depends on arrangements with client/on exterior glass or from the room side. Exception - glass with Pilkington Activ™ coating, sticker solely on interior glass.	When assembling glass units, it is necessary to follow the content of sticker: „glaze this side outside“ or „glaze this side to the inside of the building“. Labels are easily removable, within first dozen weeks from delivery.
38.	Position of solar control coatings	In position #2, inside the multiple glazed unit.	We do not recommend the use of reflecting coatings in position #1.
39.	Placement of identification marking on safety glass	By default on all pieces of toughened glass, heat strengthened glass, heat-soaked toughened glass, enamelled glass or with screen printing - permanent marks identifying type of safety glass and manufacturer are placed in one of the corners.	Repeatable positioning of mark in the corner specified by the client - requires arrangements before the order is placed.
40.	Packing method	Metal racks, for unloading with fork lifts.	As for very large or heavy glass units - unloading must be arranged.
41.	Type of car	As per arrangements with client, a car with self-unloading device is possible.	
42.	Packing, storage, installation, exploitation	In accordance with „Instructions of transport, storage, installation, use and maintenance of glass products by Pilkington IGP Sp. z o.o.“ and other available on www.pilkington.pl	

March 2021

elaborated by:

Krzysztof Skarbiński

Quality Director

Pilkington IGP Sp. z o.o.

phone: +48 601 506 051

e-mail: Krzysztof.Skarbinski@pl.nsg.com

18 Annex 3: Criteria for quality assessment of glass products

Annex 3: Criteria for quality assessment of glass products manufactured by Pilkington IGP Sp. z o.o.

General provisions

Following we present information to explain the correct procedure to control and assess the quality of glass delivered by Pilkington IGP Sp. z o.o. with acceptable tolerances for glass manufacturing and phenomena that may occur while using the products. The collected information shall be useful in answering the questions about the quality of the glass that may arise before, during and after the installation of the glass.

The described principles of assessment result directly from the applicable European standards for types of glass and base on rules used for many years on the European market.

Generally, the quality parameters declared below by Pilkington IGP Sp. z o.o. ensure higher standard of the product compared to the standard and market requirements.

The given amounts, sizes and types of all acceptable defects refer only to standards products of Pilkington IGP Sp. z o.o.

In the case of products for special applications (fireproof, bulletproof, anti-burglary, safe, structural, enamel coated, with additional internal elements such as bars, blinds, etc.) - other assessment criteria may apply, resulting from the characteristics of the product and the materials used.

If the quality requirements of the Buyer are different than those specified in these Criteria and in the standards specific to the product, Pilkington IGP Sp. z o.o. shall confirm such deviation before proceeding with the contract.

The presented method of glass assessment is also a basis for evaluation of the justifiability of submitted complaints.

In accordance with the „General Terms and Conditions of Contracts Pilkington IGP Sp. z o.o. „ and „General Terms and Conditions of the Standard Warranty for Insulating Glass Units Manufactured by Pilkington IGP Sp. z o.o.“ the Buyer is obliged to record in the Delivery Acceptance Protocol any observed scratches, breaks or cracks of the insulating glass unit and/or individual glass units. Lack of such remarks in the Delivery Acceptance Protocol may cause rejection by Pilkington IGP Sp. z o.o. of possible complaints and other claims arising from such defects. The Buyer shall test the quality of delivered products within 14 days of their delivery, before further processing.

1. Method of assessment the quality of insulating glass and single glass units

The defects are assessed by looking through the glass at a right angle, with the glass in vertical position and bright diffused lighting. The assessment is performed from min. 2 m distance, on a solid grey background or against a cloudy sky. Only product defects, visible in these conditions, are assessed for compliance with the requirements specified by Pilkington IGP Sp. z o.o.

For the purposes of glass quality assessment, the glass surface is divided into three conventional areas: edge (K), border (B) and main (G).

K = 15 mm (zone that in most cases is covered by window frame)

B = 50 mm (edge area)

G = central area of the glass

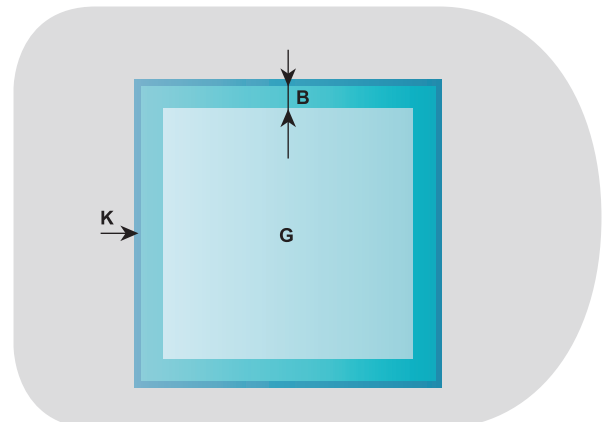
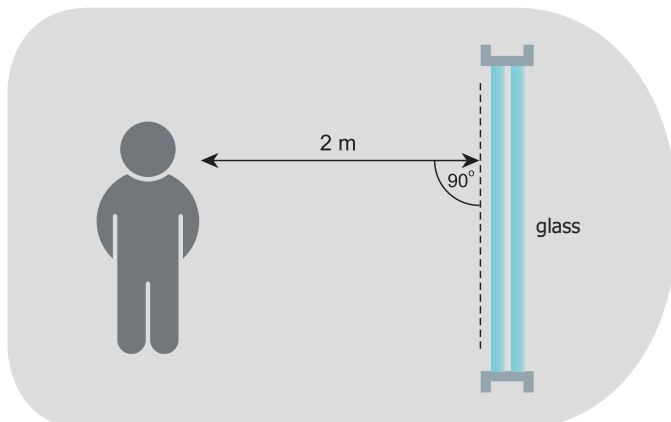

2. Acceptable tolerances for the manufacturing of insulating glass and single glass units

Table 30. Acceptable defects visible from a distance of 2 m

Defect name	K Edge area [15 mm]	B Border area [50 mm]	G Central area of glass
Hair-scratches	acceptable, without limits	acceptable but not accumulated	
Scratches		scratch ≤ 30 mm acceptable, the total length of the scratches ≤ 90 mm	scratch ≤ 15 mm acceptable, the total length of the scratches ≤ 15 mm
Point defects Ø [mm]			
Ø ≤ 0,5	acceptable, without limits	acceptable	
0,5 < Ø ≤ 1,0		acceptable, not accumulated	
0,5 < Ø ≤ 2,0		1 pc/lm for each side of the glass	2 pcs/m ² max. 5 items
> 2,0		not acceptable	

Table 31. Permissible tolerances of dimensions and thickness of insulating glass units.

Parameter	Acceptable tolerance
Dimensions	+2,0/-1,0 mm
Thickness	± 1.0 mm (annealed glass) ± 1.5 mm (toughened glass, laminated glass, patterned glass)
Diagonal difference	< 2 mm/m
Glass displacement	< 2,0 mm

Other defects

Glass dirt

Except for the edges area, dirt inside of product visible from a 2 m distance, larger than indicated in the table of defects, is not accepted.

Chipping, dents, edge damages

On not-treated glass edges, damage is allowed up to 2 mm and 20% of the glass thickness, and individual chips are accepted up to 6 mm. Cracks, even small ones - are unacceptable and should be reported on delivery protocol.

Spacer bars faults

The internal surfaces of the spacer bars should be free of stains, spots visible from a 2 m distance. In standard insulating glass, the distance of spacer bar to the edge of the glass shall not exceed 15 mm. The distance of the bars to each other or to the edge of the glass should not vary by more than 2 mm for a given side of the glass length. Deviation from the straightness of the spacer bar shall not exceed 2 mm.

Defects related to Georgian bars / Sprossen

The decorative bars installed inside the insulating glass may show vibrations and sometimes cause noticeable clicking noise. Depending on the type of decorative bar and technical possibilities, small transparent silicone elements are attached in the connection points of the bars, which dampen vibrations and knocking sound. In the case of strong external vibrations transmitted to the glass (e.g. passing a heavy car) or by opening/closing windows and doors, these protections may be insufficient to full eliminate the knocking sound.

Unsealing

Unsealing is a defect of the insulating glass unit consisting in the loss of internal tightness of the insulated glass chamber. Such defect is signalled by visible (permanent or periodic) fogging inside the insulated glass, as well as accumulation of water in the bottom part of the cavity. The tightness guarantee granted by Pilkington IGP Sp. z o.o. for insulating glass units covers only such cases when the loss of tightness is caused due to defective manufacturing of product or material defects in the delivered insulated glass, if those defects were caused by Pilkington IGP Sp. z o.o.

3. Physical phenomena associated with the using of insulating glass units, which are not caused by the poor quality of the product

Thermal cracks

Cracks caused by thermal stress occur in the event of sudden temperature changes of glass surface. The risk of thermal cracks increases when blinds, adhesive foils are installed, and when radiators

or air conditioners are pointing directly at the glass. Thermal cracks can also occur when the glass units are exposed to strong sunlight and high temperatures during transport or storage.

Image distortion in reflected light

After the insulating glass unit is manufactured, natural changes in outside temperature and air pressure increase or decrease the gas pressure inside the unit. The reaction to these changes of internal pressure may be the convex or concavity of the glass surface. Such deflection of glass surface may be noticed as distortion of the reflected image.

In extreme cases, too high pressure inside the insulating glass may result in self-breakage of the component glass. In order to prevent such problems, it is crucial to select the proper glass structure and type of glass used for the anticipated dimensions of the glass and operating conditions.

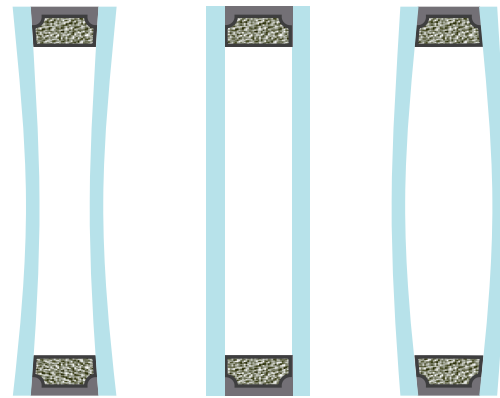

Moisture condensation / fogging of the outside surface of glass

Moisture condensation / fogging on the outside surface of the glass is a natural phenomenon associated with the position of the glass and very good thermal insulation parameters of the unit (U-value). The occurrence of such phenomenon confirms the parameters and is not deemed as a defect of the insulating glass. Similar, in such conditions may occur traces of stickers, distance elements which disappear when the glass is dry.

Moisture condensation / fogging of inside surface of the glass

The effect of fogging the inside surface of the glass is caused by too high humidity inside the room and is not deemed as a defect of the insulating glass unit.

Anisotropy / Leopard spots

The anisotropy effect can be observed in toughened glass and in insulating glass units with the toughened glass. During the toughening process, areas with different stresses are generated on glass pane. The stress areas produce the effect of birefringence in glass, visible in polarized light. When observed in polarized light, areas with different stress appear as coloured zones, sometimes called „leopard spots“. The effect could be visible for human eyes because light polarization may occur also in normal daylight, and the degree of polarization of light depends on the weather conditions and angle of sunlight. The birefringence effect increases when observed at an angle or through polarized glasses. Anisotropy is not a defect but is a visible effect of the glass toughening process.

Fine colour differences of insulating glass units

The facades made of glass units with coatings may present fine, different shades of the same colour. This effect may be strengthened when observing the glass at an angle. Such small differences may be caused by tiny changes in the colour of the ground glass on which the coating is applied and by slight differences in the thickness of the coating itself. The shade difference can be objectively assessed based on measurements in accordance with ISO 11479-2.

4. List of reference standards for the quality assessment of glass products manufactured by Pilkington IGP Sp. z o.o.

- For insulating glass: EN 1279-1 "Glass in building. Insulating glass units. Part 1: Generalities, system description, rules for substitution, tolerances and visual quality."
- For toughened glass units: EN 12150-1 "Glass in building. Thermally toughened soda lime silicate safety glass. Part 1: Definition and description."
- For float glass units: EN 572-8 "Glass in building. Basic soda-lime silicate glass products. Supplied and final cut sizes."
- For coated glass units: EN 1096-1 "Glass in building. Coated glass. Part 1: Definitions and classification."
- For laminated glass units: EN ISO 12543-6 "Glass in building. Laminated glass and laminated safety glass. Appearance."
- For heat strengthened glass units: EN 1863-1 "Glass in building. Heat strengthened soda lime silicate glass. Part 1: Definition and description."
- For heat soaked thermally toughened glass units: EN 14179-1 "Glass in building. Heat soaked thermally toughened soda lime silicate safety glass. Part 1: Definition and description."

5. CE marking and Declarations of Performance for glass products manufactured by Pilkington IGP Sp. z o.o.

Each product of Pilkington IGP Sp. z o.o. has a label with the CE marking, identification data, identification number and declared parameters. The product Declaration of Performance shall be downloaded from www.pilkington.com/CE by entering the identification number from the label. The "Transport, storage, installation, use and maintenance instruction for glass products" is available at www.pilkington.pl.

• Final provisions

The main intended use of glass products produced by Pilkington IGP Sp. z o.o. is their installation in windows, doors, walls, glued glazing for doors, windows, and walls, in roofs and partitions. Responsibility of Pilkington IGP Sp. z o.o. is limited to delivering the product in accordance with the order, of agreed quality and parameters. Pilkington IGP Sp. z o.o. does not guarantee that the product acquired by the Buyer will be suitable for specific purposes assumed by the Buyer or for use in specific conditions and place, even in a situation where such purpose or conditions may be known or disclosed to Pilkington IGP Sp. z o.o.

16 June 2020

Krzysztof Skarbiński

Quality Director

Pilkington IGP Sp. z o.o.

phone: +48 601 506 051

e-mail: Krzysztof.Skarbinski@pl.nsg.com

19 Annex 4: Information for the users of Insulating Glass Units (IGUs) manufactured by Pilkington IGP Sp. z o.o.

Information for the users of Insulating Glass Units (IGUs) manufactured by Pilkington IGP Sp. z o.o.

Below we provide a list of silicones and mounting adhesives that have been positively tested for compatibility with sealing compounds used in IGUs manufactured by Pilkington IGP Sp. z o.o.

Putting of a certain substance on the list means that tests performed according to Rosenheim Guideline DI-01/1 p. 4.1 have shown no impact tested substance in direct contact with the compounds we use to seal the glass units. Pilkington IGP Sp. z o.o. don't take the responsibility for our recommendation, if the true way use of silicones and mounting adhesives will be results in differ as in DI-01/1 Guideline conditions and proceed reaction with seals of IGUs. In case of doubts, a best way is to perform tests of final product.

For obvious reasons Pilkington IGP Sp. z o.o. cannot guarantee repeatability of results in case of changes in the composition or properties of the substance compared to the tested batch. In order to avoid possible risks, we recommend that you retest before using a new batch of the substance. Pilkington IGP Sp. z o.o. offers its assistance to help you out with the performance of required tests at no charge.

The following list of battle-tested silicones and mounting adhesives represents our state of knowledge at the time of drawing up the list. There are many substances available on the sealant market that can be used in window and facade glazing, and new solutions, and new types of substances are constantly offered by new manufacturers.

Given the above, the presented list should be treated as open and subject to update as more substances are submitted for testing. The fact that a certain substance is missing from the list does not necessarily mean that its incompatibility has been confirmed. The reason for the failure to add a substance to the list may be the lack of test results for the compatibility of this substance with sealing compounds used in all Production Divisions.

As a standard Pilkington IGP Sp. z o.o. uses polyurethane masses for sealing Insulating Glass Units (IGUs), so the first list refers to the compatibility with polyurethanes. The adding of a particular adhesive or mounting silicone to the list means that it is compatible with standard Insulating Glass Units (IGUs) manufactured in all Pilkington IGP Divisions.

This list does not preclude an option of agreeing an individual list of approved adhesives and mounting silicones with a certain customer, particularly where the customer is served by a single manufacturing site of Pilkington IGP Sp. z o.o. The arrangements to this extent are made by the sales representatives looking after the customer in question.

A separate group of IGUs manufactured by Pilkington IGP are those sealed with structural silicone. The application of this sealant is a non-standard solution and must always be clearly indicated in the customer order. There is a separate list of compatible materials for IGUs sealed with silicone, manufactured on all sites of Pilkington IGP Sp. z o.o.

Table 32. List of silicones and mounting adhesives compatible with standard Insulating Glass Units manufactured by Pilkington IGP Sp. z o.o. (sealed with polyurethane compounds)

Manufacturer	Material
DOW	DOWSIL™ 779 EU Glaze and Go neutral Sealant
Sika	Sikasil® WT 470
Sika	Sikasil® WT 480
Sika	Sikasil® WT 40
Dana Lim	Montage Extra 292
Dana Lim	Danafix Window SG60
ARA Technik	Durasil® 794 F
Würth	PURLOGIC® TOP

Table 33. List of silicones and mounting adhesives compatible with standard Insulating Glass Units manufactured by Pilkington IGP Sp. z o.o. sealed with structural silicones

Manufacturer	Material
ARA Technik	Durasil® 794 Plus
DOW	DOWSIL™ 993 Structural Glazing Sealant, DOWSIL™ 895 Structural Glazing Sealant, DOWSIL™ 121 Structural Glazing Sealant, DOWSIL™ 3362 Insulating Glass Sealant, DOWSIL™ 3362HD Insulating Glass Sealant, DOWSIL™ 3363 Insulating Glass Sealant, DOWSIL™ 3793 Insulated Glass Sealant, DOWSIL™ 791 Silicone Weatherproofing Sealant, DOWSIL™ 791-T Silicone Weatherproofing Sealant, DOWSIL™ 797 Silicone Weatherproofing Sealant, DOWSIL™ 756 SMS Building Sealant, DOWSIL™ 757 Silicone Weatherproofing Sealant, DOWSIL™ 776 InstantFix WB, DOWSIL™ 813C Construction & Concrete Silicone Sealant DOWSIL™ 799 EU Glaze and Go neutral Sealant

Note: check at www.pilkington.pl, if this document version is valid.

Kraków, 05 may 2021

Prepared by:
Krzysztof Skarbiński
Quality Director

Pilkington IGP Sp. z o.o.
phone: +48 601 506 051
e-mail: Krzysztof.Skarbinski@pl.nsg.com

20 Annex 5: Instructions of storage, transport, installation, use and maintenance of glass products

Instructions of storage, transport, installation, use and maintenance of glass products produced by Pilkington IGP Sp. z o.o.

In order to maintain confidence in the quality of our glass, we provide you with basic information on the principles of installation, operation and cleaning of our products. These guidelines refer to standard applications of glass in building facades, i.e. vertically installed, with natural access to light, air and water flow. The guidelines are based on the principles of the European Union's policy of avoiding direct exposure to volatile or liquid aggressive chemicals, high temperatures, dust and fumes that cause degradation of the glass surface or persistent raids. In the case of operating the glass in non-standard conditions, Pilkington IGP Sp. z o.o. shall not be liable for possible accelerated wear or damage to the glass, unless it was previously reported at the contract negotiation stage.

Please contact our sales representatives and advisors for information on the various types of Pilkington products, as well as relevant standards and professional literature on our products, to clarify any doubts or questions.

1. The storage of glass and the Insulating Glass Units (IGUs)

The single glass and the glass units should be kept in covered, dry, and ventilated areas, which are protected from direct effects of solar rays and precipitation.

The above-mentioned items should be kept on metal racks with carrying capacity appropriate to the load transported on them. The construction of racks should provide an equal support and the prop on the crossbars for the glass in transport. The glass must not be in direct contact with metal or any other hard materials. Lower crossbars, supporting the glass, should make the straight angle with slats from the back of the rack. The construction of the stand should provide deflection of an angle of the glass, in amount of 5 – 7 degrees from the plumb-line. The elements of rack which are in direct contact with the glass should be covered with cushioning material e.g. the rubber or wood so to eliminate potential damages of the glass.

General rule which must be adopted at packing the glass and glass units on the racks, indicates that the glass must be placed on a longer side of the glass form. The recommended order of arranging the glass on a stand is; from the highest to the lowest, when arranging from the back of the rack.

The individual forms of glass or the glass units should be separated, with a distance inserts providing the distance of the minimum 3 mm between the glasses, so that to protect them from direct contact of the subsequent glass. Inserts should be made from a material resistant to the impact of moisture.

Upon storage, the glass must be protected from the effects of aggressive chemical agents, or physical and mechanical interactions leading to damage or decrease in quality and durability of glass.

Double glazing racks should be set so that both glass components are propped properly. In the case of different levels of glazing, the narrower pane must be supported by an underlay pads, e.g. wooden, equalizing the two dimensions of glasses.

During the storage or performance of any other warehouse actions, glasses must be attached to the stand with the use of a tape hoops to eliminate the risk of tipping over of glasses even when they are tilting from the plumb – line. Do not use a metal tape to protect the glass on the stands. Plastic tapes with suitable strength can be used for that purpose, in the places of contact with the side of the glass, a plastic or cardboard distance inserts should be used.

During the storage of glass a force of press securing elements should not be too big so to give the possibility to compensate for changes in thickness of sets, associated with changes in temperature and pressure.

2. Transport of glass and IGUs

Transportation of the glass units should be performed on a metal transport racks, in a way that provides protection against mechanical damage to a cargo. Automobile means of transport with pneumatic suspension and closed body should be utilised for glass transport.

Racks with glass must be set up parallel to the axis of the car, keeping indispensable distance between the stands and glasses. Mounting glasses to the racks and racks to the body of the car should ensure no risk of load shifts, even in the case of strong braking. The body of the car should ensure the protection of cargo from the solar rays, precipitation and incursion, between the glasses, of big particles of hard materials which can cause damage to the surface of glass.

3. Information on basic rules of conduct during glass assembly:

- a) the glass products assembly should be carried out using manual and mechanical means for carrying glass, which are adapted to the dimensions and weight of the glass and guarantee the safety of people and environment,
- b) assembly procedure - according to the instruction equipment for manual or mechanical glass handling,
- c) in order to prevent the formation of hard to remove traces on the glass surface, any labels or stickers on the glass surface must be removed immediately during glass installation,
- d) during assembly work, it must be ensured that the glass does not come into direct contact with metal parts and that there is no risk of possible mechanical damage to the glass,
- e) glass should not be subjected to the influence of chemical compounds aggressive to glass and mechanical actions, e.g. scratching, impact - which may lead to damage to the glass itself or to changes in the performance characteristics of the materials used to make the insulated glass. If, during installation and operation, the glazing is exposed to the release of basic substances, silicates and products containing fluorine or fluorine-based acids that cause chemical damage to the surface of the glazing, dirty glass must be washed immediately to avoid such situations. This requirement also applies to the method of glass cleaning and maintenance,
- f) the sealants and fillers, gaskets, washers and other materials used in the assembly of insulated glass, which may come into direct contact with the edges of glazing units, shall be compatible with the materials used in the manufacture of insulated glass. This type of materials may contain large quantities of unknown solvents or plasticizers, which are released during curing and react aggressively with the substance used as an external sealant in the manufacture of insulated glass,
- g) the method of fixing the insulated glass shall ensure permanent coverage of the entire edge band around the glass, in such a way as to protect them from direct sunlight exposure to the sealing compound of the insulated glass. This condition does not apply if, at the stage of glass ordering, it was agreed to make the glass with the use of sealing materials with permanent UV resistance (silicone compounds).

The rules for setting the glass on the racks - as for the storage of glass. At the time of transport, the force of press at fasteners should be increased so that to protect the glass against shifts.

The method of fixing the glass must be in accordance with EN 12488 and ensure effective ventilation and drainage of water from the area around the edge of the glass, so as to exclude long-term exposure to water or steam with the glass sealing materials or laminated glass interlayer.

The weight of the glass shall be transferred to the fixing structure by means of two rigid supporting elements, each of the insulated glass must be supported. The fastening, supporting and clamping elements shall be at least 50 mm from the corner of the glass.

4. Glass operation

Unless otherwise agreed, it is assumed that all two-way glass (single and multiple insulated glass) will be operated in a vertical position under conditions which ensure full natural flow of light and heat from the sun through the glass. Under such conditions, naturally occurring temperature differences between the sunny part of the glass and the shaded part do not lead to cracking of the glass. However, attention should be paid to the presence, both externally and internally, of objects or elements which permanently differentiate the heat flow through the

glass. Their presence causes a local accumulation of solar heat in this area of the glass, which can lead to accelerated wear and thermal cracking of the glass (not applicable to toughened or heat strengthened glass). Elements that can cause such phenomena are e.g. opaque foils, posters glued to inner glass panes, heat-emitting elements placed close to the glass (lamps, displays, kettles, heaters, fans, etc.), furniture and display cabinets blocking the heat flow, blinds, suspended ceilings.

5. Glass cleaning

- a) Glass should be washed with water and commercially available glass cleaners.
- b) The basic principle is to rinse the glass with plenty of clean water, both before, during and at the end of washing. Avoid mechanical rubbing of the surface of the glass with sand, dust, mortar, etc. In such situations, remove these particles first with a strong jet of water and then wipe the glass surface. It is forbidden to use any metal or ceramic scraper to remove dirt from the glass, as well as pastes and solutions containing abrasives that may scratch the glass surfaces.
- c) Dirt which cannot be removed as described in point (b) may be cleaned with soft brushes, rubber, leather or fine industrial steel wool without abrasive additives - after making sure that it does not cause damage to the surface of glass.
- d) Spirit, isopropyl alcohol, acetone or petrol may be used to remove dirt from paint, tar, etc. After using the above-mentioned agents, the surface of the glass should be washed with water and wiped dry, however, it should be ensured that these liquids do not come into contact with other elements, e.g. varnish covering aluminum structures.
- e) Do not use alkaline and acid solutions, especially liquid acids and cleaning agents containing fluorine and chlorine, which may cause irreversible damage to the glass surface.
- f) The glass cleaning should be carried out regularly, depending on the degree of soiling. It should be taken into account that as time passes, any dirt, stains or raids on the glass surface may become more and more difficult to remove, thus increasing the risk of glass damage during cleaning.
- g) It should also be remembered that glass washing operations must be carried out in such a way that both the person washing the glass and the equipment used by him/her do not cause excessive pressure or impact on the glass, as they may cause the glass to break or cause permanent scratches. All tools used during glass washing, especially suction cups, should be made of a suitable type of material, not leaving hardly removable marks on the glass.
- h) When using liquids, pastes, chemical mixtures, etc. other than pure water to clean the glass, an initial test should be carried out on a small area of the glass before starting work to ensure that they do not cause damage to the glass, gaskets and varnish coatings.

21 May 2020

prepared by:

Krzysztof Skarbiński

Quality Director

Pilkington IGP Sp. z o.o.

phone: +48 601 506 051

e-mail: Krzysztof.Skarbinski@pl.nsg.com

21 Annex 6: Quality assessment criteria for ScreenLine® integrated blinds

ScreenLine® blinds have at least 2.5 mm of space on each side between the slats and the spacer.

This allows the system to move freely and allows for the thermal expansion of the aluminium slats.

Manufacturing tolerances for ScreenLine® blinds are as follows:

Width: 0 mm / -1 mm

Height: > +8 mm ≤ 0 mm

Caution: The height difference is determined by the pitch of the belt ladder.

Due to the sum of the tolerances of the cable diameters and the internal winder, the bottom rail may tilt slightly when the blind is lifted.

The tilt is more conspicuous in tall, narrow blinds.

Parallelism tolerances for the lower rail

According to EN 13120, the maximum permissible inclination of the lower rail with respect to the centre point is +/- 7.5 mm (15 mm in total) for all of the blind's positions. ScreenLine® system production standards define measurement of tolerance in three positions.

Lower position +/- 2 mm

Middle position +/- 5 mm

Upper position +/- 7 mm

The tolerance is to be calculated in relation to the central point of the lower rail.

Deflection tolerances for the lower rail

According to EN 13120, the maximum deflection of the bottom rail and the slats (measured at the central point) depends on the width of the blind. The acceptable values of deflections are presented in the table below.

The width of the Venetian blinds	Deflection of the slats and bottom rail
less than 1.5 m	5 mm
between 1.5 m and 2.5 m	10 mm
over 2.5 m	15 mm

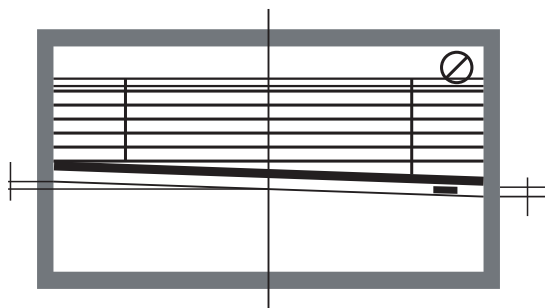

Fig. 32. Lower rail parallelism.

As a result of the lifting lines and strap ladder shrinking, the lower rail may eventually be lifted. It should be remembered that the materials from which the strings and strap ladders are made shrink when the temperature drops and expand when the temperature rises. The length variation index for these materials is approximately 0.02% /°C. For example: if the temperature of a 1000 mm blind is 50°C higher than the factory temperature, the blind will expand by 10 mm. The same rule applies to the tilting blinds mechanism (i.e. blinds with the bottom rail blocked). When the blinds are lifted, the tapes are wound irregularly and at a different pace, which may cause the slats to deviate from the horizontal position during lifting.

Partial tilt of the slats

According to EN 13120, the permissible number of slats that are not fully tilted is 2% of the total number of slats in the blind. It may happen that the slats get stuck when lowering the blind and will not tilt into the required position until they are fully lowered. This is acceptable as long as the number of slats that are in the wrong position when the blind is lowered is within the values shown in the table below.

Number of slats in the blind	Max. number of fully tilted slats
Less than 500	0
50 - 100	1
100 - 150	3
150 - 200	4
Over 200	5

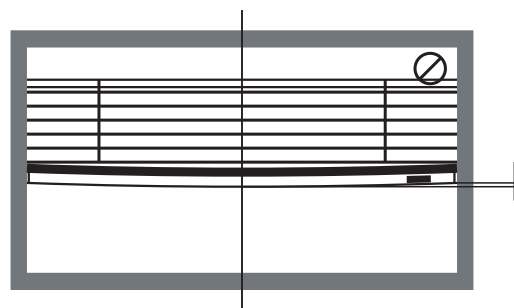

Fig. 33. Central deflection of the lower rail.

Height of the blind	Tolerance	Minimum angle in closed position
Up to 1 m	5°	55°
Over 1 m	10°	50°

Angle of the slats in the closed position

The tilt of the slats determines the amount of light that is let into the room. The tilt of the slats is changed by the movement of the strap ladders.

The angle of the slats in the closed position must be at least 60° in relation to the axis perpendicular to the plane of the inner pane. The angle tolerances in the closed position depend on the height of the blind:

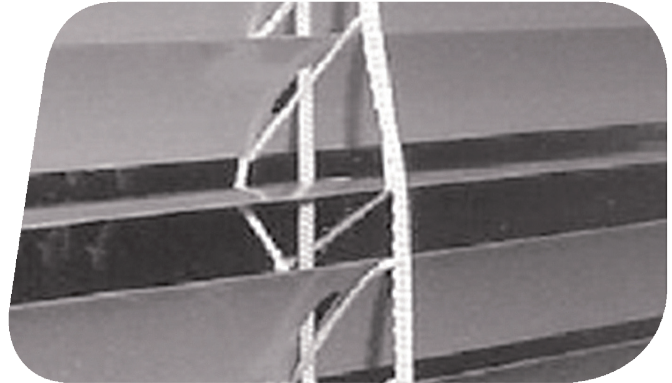

Instructions on how to check that the slat closed position is correct are given below:

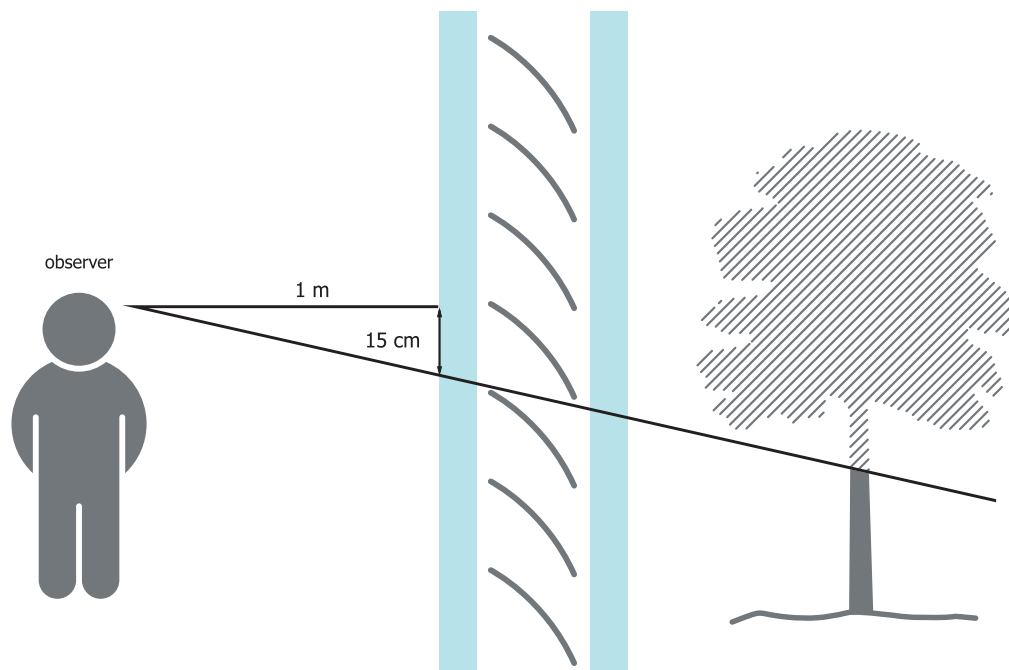

- Close the slats completely with the concave side facing inward.
- Define a line on the blind that matches your eye level, and then stand 1 m from the inner glass pane
- Look at the area masked by the slats.
- All objects behind the area at least 150 mm below the line of sight should be invisible to the observer (this corresponds to the tilt of the slats of about 60°).

Caution: As a result of the above-mentioned tolerance, differences in the degree of closure of the adjacent slats can occur.

Tilt angle of the slats

Tilt of the slats must be at least 90° in relation to the longitudinal axis of the slats.

Overlapping of the slats

With the maximum closing angle of 60°, the individual slats must overlap by more than 1 mm.

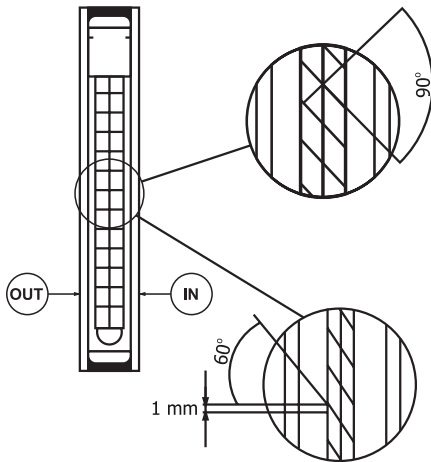

Fig. 34. Tilt angle of the slats.

Parallelism of the slats

The maximum differences in the horizontal position of individual slats must not be greater than 2 mm per running metre.

Measurements should be taken at several places on the blind with the slats in horizontal position (see: EN 13120)

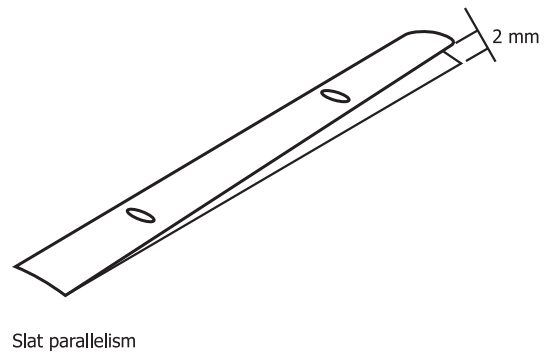

Fig.35. Parallelism of the slats.

Tolerances for external control

Unless specified in a special order, the outer control line shall end 65 mm from the line of sight, with a tolerance of +10 mm/-20 mm. external length tolerance of the rotary bar with the length specified in the catalogue is +5 mm/-5 mm.

Non-compliance

Non-compliance assessment of ScreenLine® products must be based on visual inspection of the blind installed in the space between two glass panes. The assessment applies only to the visible elements of the blinds (main rail, slats and spacers, as long as they are part of the ScreenLine® system set). The assessment does not include the quality of the glass panes.

Assessment procedure

The quality assessment of the blind must comply with the following provisions:

- Insulating glass units with blinds must be located in a vertical position, according to their usage specification.
- The blind must be lowered and the slats tilted at an angle of about 45°.
- When observing from both sides, the observer must be 2 m from the glass and their line of sight must be perpendicular to the surface of the glass as shown in the figure below.
- Prior to making the assessment, do not mark any points where there may be a potential nonconformity.
- Assessment should not be made when direct sunlight is falling on the slats.

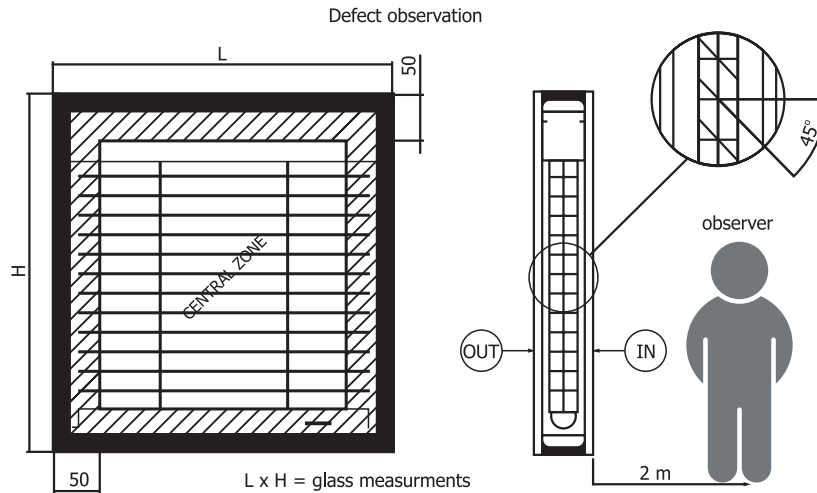

Fig. 36. Observation of defects.

Criteria of acceptance

The surface of the insulating glass unit should be divided into two zones: the peripheral zone and the central zone (shown in the figure above).

Peripheral zone: a 5 cm wide frame around the glazing unit. This zone includes the main rail and the bottom rail of the blind, the ends of the slats and the material, as well as the spacer.

Central zone: covers the remaining area (all except the peripheral zone). This zone contains the central part of the blind that should have the lowest number of defects. As far as the components of the blind are concerned (main rail, slats, material and bottom rail), the possible defects are listed below. However, it should be remembered that the total area of the insulating glass unit should be rounded to the next whole number.

Peripheral zone

Inclusions, stains, paint-related defects: a maximum of 1 defect with a maximum size of 3 mm for each square metre of the insulating glass unit.

Sediment on the slats/stains on the material: a maximum of 1 defect with a maximum size of 3 mm for each square metre of a double glazed insulating glass unit. In the case of dirt on the ends of the slats, the criteria described in the section below "worn places due to rubbing against the side spacer" should be applied.

Scratches/marks on the material light, not very conspicuous scratches are acceptable, provided that their total length does not exceed 30 mm. The maximum length of a single scratch must not exceed 15 mm.

Central zone

Inclusions, stains, paint-related defects: a maximum of 1 defect with a maximum size of 2 mm for each square metre of the insulating glass unit.

Residue on the slats/stains on the material: a maximum of 1 defect with a maximum size of 2 mm for each square metre of a double glazed insulating glass unit.

Scratches/marks on the material at most 2 light and not very conspicuous scratches are acceptable, provided that none of them exceeds 10 mm in length.

Worn places as a result of rubbing against side spacers:

Continuous rubbing of the slats against the side spacers during the movement of the blind causes the deposition of a dark residue on the slats over time. It is aluminium dust that comes from the side spacers. Side spacers in the ScreenLine® sets are specially protected by a method patented by Pellini. The solution has been introduced to reduce and hence delay the formation of residue and to preserve the colour of the slats near the side spacers where they come into contact with the blind slats. This protection is resistant to solar radiation and does not induce tarnishing.

As for abrasion and the associated black residue on the slats, a directive from the IFT Rosenheim institute is attached below, which defines the acceptable limits for the black residue and change of the slats' colours related with this residue.

1. Check if 10% of all slats are discoloured at the tips. Focus on the dirtiest slat.
2. Determine the extent of the discolouration based on **Table 34**.
3. Determine the colour of the slats based on **Table 35**.
4. Determine the colour of the dirt based on **Table 35**.
5. Determine the difference between the colour of the slats and the colour of the dirt on the basis of the obtained values.
6. Check in **Table 36** if the discolouration acceptance criteria have been met.

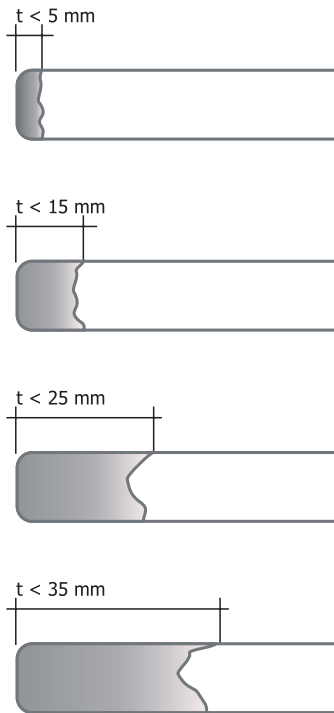

Table 34. Level of dirt on the tips of the slats (t).

	0 - 20%
	20 - 40%
	40 - 60%
	60 - 80%
	80 - 100%

Table 35. Slats' colour and the colour difference Slat colour/Dirt colour, difference.

Discolouration range	Difference of colours				
	0-20%	20-40%	40-60%	60-80%	100%
t ≤ 5 mm	Yes	Yes	Yes	Yes	Yes
t ≤ 15 mm	Yes	Yes	Yes	Yes	No
t ≤ 20 mm	Yes	Yes	Yes	No	No
t ≤ 35 mm	Yes	Yes	No	No	No
t > 35 mm	No	No	No	No	No

Table 36. Acceptable discolouration for the slats.

If you cannot definitely decide between two colours in the table, choose the lighter one.

Example

Suppose the strip has a colour similar to the first colour in Table 35. In this case, the colour contrast is assessed at 0–20%.

If the colour of the dirt on the slat is similar to the colour in the last picture in Table 35, the colour contrast in that case is between 80% and 100%.

The difference is 80%, so according to Table 36, the darkest dirt can cause the slat colour change up to 15 mm in length.

Material corrugation

Both the motorised version of the SL27 Rullo (System M) and the line-operated version (System C) can introduce material corrugation near the side spacers between which the blind travels.

Corrugation of the material is visible from a short distance (less than two metres) with an observation angle of less than 90° in relation to the glass surface. Corrugation is not considered a defect if it does not adversely affect the correct operation of the system (i.e. the blind works properly when lifting and lowering).

Special Applications

ScreenLine® sets are intended for installation in rectangular, vertically arranged insulating glass units.

Special applications are also possible:

- inclined and horizontal insulating glass units,
- insulating glass units of various shapes,
- structural insulating glass units.

• In the case of inclined insulating glass units, the use of internal blinds with a lifting feature is not recommended.

Friction of the slats against the glass does not allow the blind to work properly and may lead to failure of the belt ladder. Therefore, in inclined units, it is recommended to use sets with pleated material or blinds that only have the tilt function (and suitable slat supports).

• In the case of insulating glass units installed in tilt windows, the blinds should not be used when the window is tilted, and in any case, a block should be installed to prevent the insulating glass unit turning upside down (windows systems with 180° rotation).

Blinds must be lifted (fully raised) before the window is tilted, and in the case of blind systems with the tilt feature only (i.e. blinds with a bottom rail fixed) the window should only be tilted when the slats are closed. For the above applications, it is recommended to use a specially designed model with pleated fabric or Venetian blinds with the tilt feature only.

• For insulating glass units installed in doors, the continuous striking of the slats on the glass can damage the belt ladders.

Therefore, it is recommended to attach shock absorbers on the doors that limit their movement.

22 Annex 7: Information on the occurrence of water vapour condensation on the outer surfaces of the glass

With reference to the complaints and comments related to the phenomenon of condensation on the external surfaces of insulating glass units, please see below the explanation for the phenomenon:

Recent breakthroughs in glass production technology have resulted in a significant improvement in the thermal insulation of window panes, expressed by ever lower values of the U heat transfer factor. Currently manufactured insulating glass units with $U=0.5\div 1.1$ W/m²K ensure very large savings in energy used for heating the interiors because only a small amount of heat escapes through the glass. As a result, the temperature of the external pane of the glass unit installed on façade is only slightly higher than the ambient air temperature.

This means that the lower the U factor for glass unit, the more vulnerable they are to the phenomenon of water vapour condensation.

The phenomenon of water vapour condensation occurs when the temperature of the outer pane is lower than the dew point temperature of the air surrounding the building.

Such situations occur mainly on cool mornings in the spring and autumn, when the night temperature drops to around 0°C. In the morning, warm wind and solar radiation cause a rapid increase in the air humidity and temperature, while façade elements with good insulating properties remain cold and warm up slowly.

The resulting large temperature difference between the surrounding air and cold objects causes the condensation of water vapour on the coldest surfaces, i.e. on windows, window frames or car bodies. In winter, this effect is rarely observed due to the low air humidity prevailing at that time.

However, immediately after opening the window sash, this phenomenon may be visible for a short time even in winter. The reason is the cold surface of the glass coming into direct contact with the moisture in warm air escaping from the room. The cold pane is then covered with a layer of condensing water vapour, which quickly disappears as the pane heats up from the warm air escaping from the room. After a few minutes, the glass becomes transparent again. During such short-term steaming, local irregularities in the condensation of water vapour may appear on the surface of the pane, visible in the form of, for example, the contours of labels previously glued on the glass or the outline of the nozzles used to transport the glass. However, all of these temporary effects fade as the glass dries out. After a few minutes, the glass returns to its normal appearance and the described effects become completely invisible.

To sum up, the periodic occurrence of the water vapour condensation on the outer surfaces of insulating glass units and the accompanying unevenness in the condensation is a natural physical phenomenon and should be treated as proof of the expected good thermal insulation properties of the glass unit. Thus, the occurrence of these phenomena cannot constitute a basis for any warranty claim about the quality of the glass or its functional features.

23 Annex 8: Information on glass disinfection

When disinfecting glass units, follow the general recommendations given in "Information on the principles of installation, operation and washing of glass manufactured by Pilkington IGP and the phenomena accompanying the use of insulating glass units and other glasses", available on our website.

The rules for selecting a disinfectant should be as follows:

- a/ must not contain concentrated acids and bases,
- b/ must not contain hydrofluoric acid or its derivatives,
- c/ must not contain solutions of alkali silicates,
- d/ each time, before disinfecting, a small amount of disinfectant should be applied to a small area of the glass surface. Wait until it evaporates or wipe it off and inspect the condition of the glass surface for the presence of any tarnish or stains,

- e/ the disinfection method must be such as to prevent the disinfectant from dripping into the seals and into the window frame.
The disinfectant used may harm sealing materials and seals, leading to their damage or degradation.

24 Annex 9: Information on the service of glass wrapping

- Insulating glass units or individual glass sheets can be covered on the client's request with a special film in order to reduce the risk of soiling the glass during transport and assembly works on the building façade. The wrapping film, however, does not guarantee protection against mechanical damage to the glass, scratching and aggressive chemicals.
- During the process of wrapping, one or both external sides of the insulating glass unit are wrapped with plastic film. The plastic used has poor self-adhesive properties, allowing easy removal after installation.
- Wrapping is a separate service, independent of the order for the production of insulating glass units or individual glass sheets.
- As a standard, the wrapping service is limited to:
 - ▶ double-sided wrapping – units up to 80 kg,
 - ▶ one-sided wrapping – units heavier than 80 kg, film can be wrapped only on the outside surface of the glass unit transported on the rack.
- The glass units/panes are wrapped either over the entire surface, or an unwrapped strip along the perimeter of the glass is left, typically 25–30 mm wide.
- Pilkington IGP warns of the risk to the safety of persons and property when using suction nozzles to handle glass panes/units covered with plastic film.
- The plastic film should be removed from the glass not later than 3 months from the date of receipt of the glass.
- Insulating glass unit wrapped with plastic film must be stored in shaded and airy places that provide protection against rain and snow.

25 Annex 10: Information for customers ordering glass products made of customer-provided glass

Pilkington IGP Sp. z o.o., besides the standard production of insulating glass units, toughened glass and laminated glass, also manufactures such products using ready-made glass sheets provided by the client (so-called client-provided glass products).

Because the client-provided glass sheets' quality of manufacture and specification remain outside of the control and responsibility of Pilkington IGP Sp. z o.o., below we present the rules defining the scope of the responsibility of Pilkington IGP Sp. z o.o. for client-provided glass and products made of it.

1. If applicable, an order for the manufacture of insulating glass units, toughened glass and laminated glass should clearly specify that they are to be made of customer-provided glass plates. As regards insulating glass units and laminated glass laminated glass, it should be clearly indicated which elements of the product structure shall be made of client-provided glass, and which are to be provided by Pilkington IGP Sp. z o.o.
2. As a rule, it should be assumed that the supplier of the client-provided glass must be the same company that places the order for the final product made of the glass.
3. With any such order, details should be enclosed of the plates' structure and thickness, and order-specific requirements that must be fulfilled in the process of the ordered product's manufacture.

If the client fails to provide the above details or provides incomplete information and the glass provided by the client incurs a damage or destruction in the process of processing because of the missing details or incomplete information, Pilkington IGP Sp. z o.o. shall not be liable to the client for the damage and/or destruction.

4. Pilkington IGP Sp. z o.o. reserves the right to refuse an order if an inspection of the client-provided glass sheets has revealed that their type, quality or manufacture may pose a threat to the proper production processes and/or the final product's required quality.
5. As a rule, it should be assumed that the customer is responsible for the provided glass plates' compliance with the relevant legal requirements and standards for the respective product type. In particular, Pilkington IGP Sp. z o.o. assumes by implication that any customer-provided glass plate is properly CE marked as declared by the manufacturer. The customer shall be entirely responsible for any legal consequence of the provided glass plates' failure to meet the formal requirements.
6. As for client-provided toughened glass sheets intended for lamination, the total convexity of the sheets shall not exceed 2 mm/m and the local convexity shall not exceed 0.2 mm/300 mm.

7. In the manufacture of a product made of a customer-provided glass, Pilkington IGP Sp. z o.o. will comply with all standards applicable to the products made of its own glass. However, since no production process is risk-free, Pilkington IGP Sp. z o.o. disclaims its responsibility for any damage or destruction of the client-provided glass incurred in the storage and production processes.
8. For any product made of customer-provided glass, IGP Sp. z o.o. gives the standard warranty guarantee available for the respective product type. Any such product is declared by Pilkington IGP Sp. z o.o. as CE-compliant and marked accordingly. This applies to insulating glass units, toughened glass and laminated glass alike.
9. As a standard, no specific performance characteristics of the insulating glass units, toughened glass and laminated glass made of customer-provided glass are declared. The only exception is the declaration of toughened glass' safety class.
10. If a customer expects Pilkington IGP Sp. z o.o. to declare a specific parameter of a finished product made of customer-provided glass, this must be reported at the inquiry stage or in the order. This will allow Pilkington IGP Sp. z o.o. to assess the possibility to declare this parameter for the finished product, and to notify the customer accordingly before the order acceptance.

26 Annex 11: Triple glazed insulating units – information on specific product features and issues requiring attention when choosing glazing design

Recent few years have brought a major change into the market of insulated glass units for construction industry. Availability of glazing with low-emissivity coating combined with legislators', investors' and users' focus on energy efficient solutions in construction industry, have led to a sharp growth in demand for glazing with very good thermal insulation properties, expressed by a low heat transfer coefficient U. The manufacturers' response for this market demand, is introduction of triple glazed insulating units into their offerings.

A standard insulated glass unit is of a double glazed type, and consists of two glass panes separated by a spacer 6 to 24 mm thick. Typically a low-emissivity coating which reflects thermal radiation coming from the room, is applied to one of the panes.

A triple glazed insulating unit is a further development of a double glazed concept, created by adding a third pane of glass with low-emissivity coating and the second spacer between the panes. A unit created in this way is characterised by a heat transfer coefficient U approximately 50% lower, which leads to a considerable reduction of heat losses through windows, and thus also reduced cost of heating.

Due to the design of a triple glazed unit, the volume of air spaces between individual glass panes grows by 100%. Those volumes, hermetically along all their edges, protect the low-emissivity coatings from contact with ambient air, and – when filled with argon gas – constitute the main barrier for heat losses through glazing.

Triple glazed units, just like double glazed ones, are hermetically sealed systems remaining in equilibrium with their surroundings, at temperature and pressure levels such as observed inside the manufacturing hall during their assembly. This means that when in use, the glass units react to every change of ambient air temperature and pressure. As a result, overpressure or underpressure occurs within units and creates mechanical load on glass panes within the unit. Such overpressure loads may be partially compensated by increasing volume of triple unit (outer glass panes bulge) or, by underpressure loads, by decreasing volume (glass panes become concave). An insulated glass unit remains stable, until effective load on glass pane exceeds permissible limiting values; upon these are exceeded, glass cracks.

A risk of insulated glass unit cracking under influence of over/underpressure depends on several variable factors:

- magnitude of difference between the actual glazing temperature and temperature during the glazing unit production process (the larger the difference, the larger the over/underpressure in the unit),
- magnitude of difference between the ambient pressure and pressure during the glazing unit production process (both natural pressure differences, like high and low pressure areas, and pressure differences resulting from difference of altitude above sea level of application and production sites, need to be taken into account),
- flexural strength of the glass panes used to build an insulated unit, which is proportional to the glass thickness and dependent on glass type (e.g. toughened glass has a bending strength some 2.5 times higher than standard glass),
- total thickness of spacers (the higher the thickness, the higher pane stress is caused by temperature or pressure change inside of glazing unit),
- glass pane dimensions and aspect ratio (the larger and/or the more square the pane is, the higher its capability to bend and compensate internal over/underpressure).

One of output after analysis of factors mentioned above is, that by similar design and dimensions of units, the risk of cracking of triple glazed insulated units is higher when compared to traditional double glazed units.

Adverse factors in case of triple glazed units include:

- twice larger volume of spaces filled with argon or another gas, which in case of over/underpressure create larger load on constituent glass panes of a unit,
- presence of two low-emissivity coating layers and very low value of U coefficient, which lead to higher temperature values inside a insulated unit during its operation, and therefore higher pressure levels inside a unit.

Regardless of these, in practice glass units are also subjected to other external loads created by wind, snow, thermal stresses, load transferred from the window or façade structure, load related to use of glass unit etc. Magnitude of those loads typically does not depend on type of a glass unit used: double or triple pane.

Analysis of customer feedback and mathematical modelling of glass behaviour allow to determine types and application areas of triple glazed insulated glass units where the glass cracking risk is significantly higher:

a/insulated glass units with the shorter edge < 650 mm;

b/insulated glass units where the internal and external panes are of different thickness.

Note: for the sake of simplification, it may be assumed that 33.1 or 33.2 laminated glass is equivalent to a 4 mm glass pane, 44.1, 44.2 or 44.4 laminated glass is equivalent to a 6 mm glass pane, and 55.1 or 55.2 laminated glass is equivalent to 8 mm glass pane.

c/insulated glass units whose temperature during operation may be > 35°C, e.g. used in hot climate or in case elements blocking free flow of solar heat are placed behind the glass (e.g. curtains, blinds, solar window films);

d/insulated glass units used at altitudes > 650 m ASL.

In case any of the situations mentioned above (a–d) occurs it is recommended to perform project-specific calculations to verify whether choice of glazing thickness and type is correct for the predicted operational loads.

If the result of calculations is negative, then in most cases a valid solution is replacing annealed glass with low-emissivity coating with toughened low-emissivity glass. This solution ensures that thickness of the insulated glass unit and declared parameters of transparency, g coefficient, U coefficient etc. remain unchanged.

It needs to be noted that using toughened glass does not reduce pane bulging, it only reduces the risk of cracking. This means, that if it is planned to install additional elements on the glazing, e.g. external glazing bars, then the problem with attaching them to a bulged surface remains.

The present Information does not exhaustively describe all issues related to choosing design and parameters of triple glazed insulated units, their transport, storage, installation and operation. It also does not provide information on criteria for evaluating quality of such units or any other phenomena which may occur when using them. On all those matters, please refer to the materials posted on our website, relevant expert publications and/or contact our consultants.

27 List of contacts

For placing orders, advice and possible complaints, we provide the following contacts:

HQ address:

Pilkington IGP Sp. z o.o., ul. Portowa 24, 27-600 Sandomierz
Tel.: 15 832 30 41
Faks: 15 832 65 45

Sales office and technical support

Pilkington IGP Sp. z o.o.

Curtis Plaza - 3rd floor
ul. Wołoska 18
02-675 Warsaw
Tel.: 22 548 75 00

Pilkington IGP Sp. z o.o. branch in Białystok

ul. Welurowa 6, Hall no.3
15-680 Białystok
Tel.: + 48 85 745 60 15
Bok.Bialystok@pl.nsg.com - Customer Service Department

Pilkington IGP Sp. z o.o. branch in Bydgoszcz

ul. Ołowiana 13
85-461 Bydgoszcz
Tel.: + 48 52 365 61 01
Bok.Bydgoszcz@pl.nsg.com - Customer Service Department

Pilkington IGP Sp. z o.o. branch in Krakow

ul. Półhanki 62
30-740 Kraków
Tel.: + 48 12 627 79 01
Bok.Krakow@pl.nsg.com - Customer Service Department

Pilkington IGP Sp. z o.o. branch in Ostrołęka

ul. Bohaterów Westerplatte 5
07-410 Ostrołęka
Tel.: + 48 29 770 45 32
Bok.Ostroleka@pl.nsg.com - Customer Service Department

Pilkington IGP Sp. z o.o. branch in Skierniewice

ul. Przemysłowa 4
96-100 Skierniewice
Tel.: + 48 46 835 05 00
Bok.Skierniewice@pl.nsg.com - Customer Service Department

Pilkington IGP Sp. z o.o. – Branch in Szczecin

ul. Pomorska 55
70-812 Szczecin
Tel.: + 48 91 466 46 01
Szczecin.Bok@pl.nsg.com - Customer Service Department

You can find business contacts on our website www.pilkington.pl under the Contacts tab.

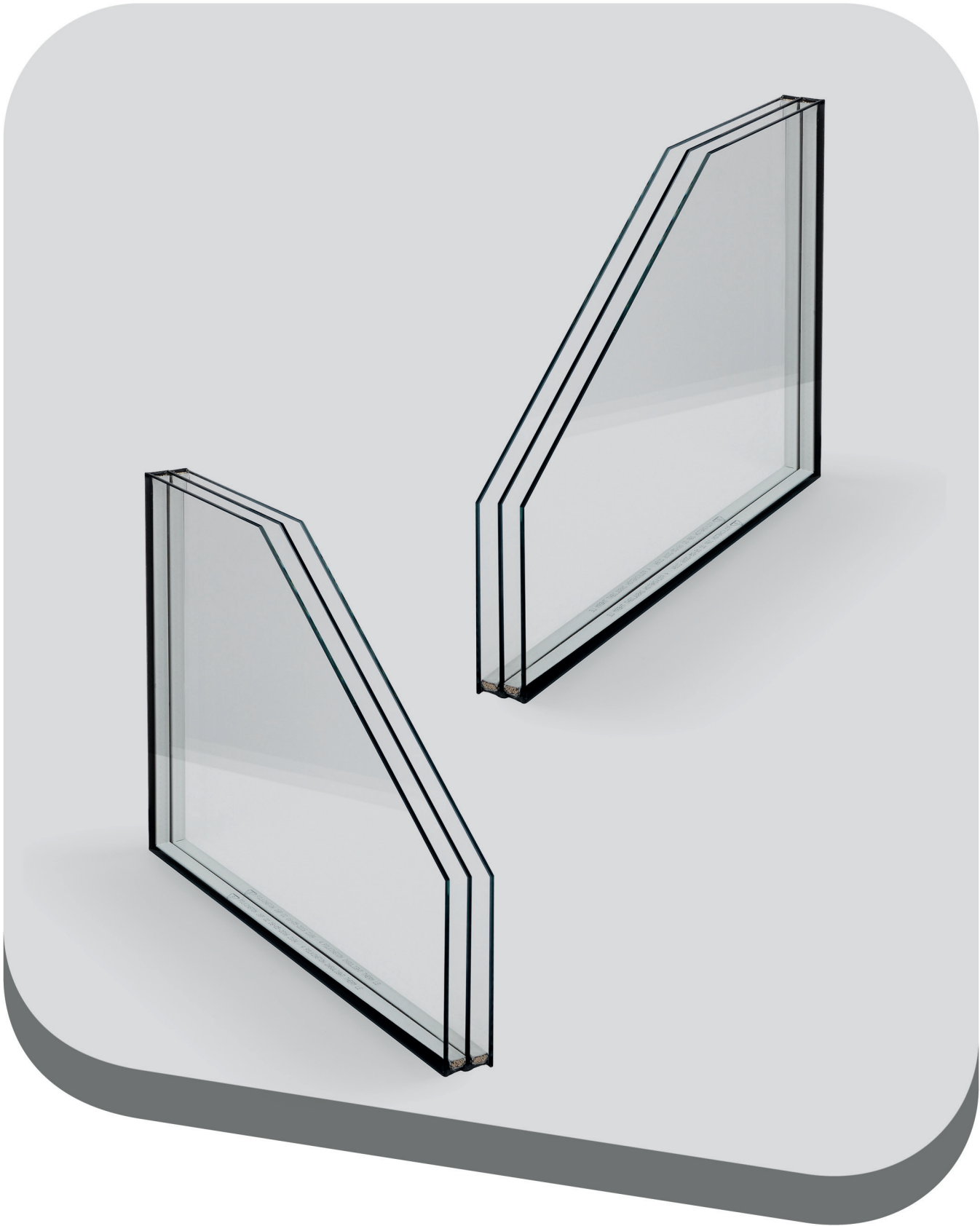

November 2021