



# Pilkington Planar™ System Information

## Single Pilkington Planar™ Laminated Safety Glass

Single Pilkington Planar™ Laminated Safety Glass  
Performance of typical combinations with clear interlayer

Pilkington T glass Plus Outer Leaf	Heat Strengthened or Pilkington T glass Plus Inner Leaf	Light Transmittance LT	Light Reflectance LR	Total Solar Radiant Heat Transmittance	Total Shading Coefficient	U Value (W/m²K)	R <sub>w</sub> Value (dB)
Pilkington <b>Optifloat™</b> Clear	Pilkington <b>Optifloat™</b> Clear						
10mm	4mm	0.83	0.08	0.69	0.79	5.4	38
10mm	6mm	0.82	0.08	0.68	0.78	5.4	39
12mm	6mm	0.81	0.07	0.65	0.75	5.3	39
15mm	6mm	0.79	0.07	0.63	0.72	5.2	40
Pilkington <b>Optiwhite™</b>	Pilkington <b>Optiwhite™</b>						
10mm	4mm	0.89	0.08	0.82	0.94	5.4	38
10mm	6mm	0.88	0.08	0.81	0.93	5.4	39
12mm	6mm	0.88	0.08	0.81	0.93	5.3	39
15mm	6mm	0.87	0.08	0.80	0.92	5.2	40
Pilkington <b>Activ™</b> Clear	Pilkington <b>Optifloat™</b> Clear						
10mm	6mm	0.77	0.14	0.64	0.74	5.4	39
Pilkington <b>Activ™</b> Blue	Pilkington <b>Optifloat™</b> Clear						
10mm	6mm	0.34	0.12	0.37	0.43	5.4	39

Technical data has been calculated according to EN 410 and EN 673. The above table has been updated to take into account the declared values of radiation and thermal properties required for CE Marking. R<sub>w</sub> Value is indicative for PVB interlayer product only and will be subject to minor variations dependent upon the size of the glass panels and the number of fittings required.

### Pilkington Planar™ Laminated Safety Glass – Glass Types

Glass Type	Colour	4mm	6mm	10mm	12mm	15mm	19mm	Notes
Pilkington <b>Optifloat™</b>	Clear	✓	✓	✓	✓	✓	✓	
Pilkington <b>Optifloat™</b>	Grey	✓	✓	✓				
	Bronze	✓	✓	✓				
	Green	✓	✓	✓				
Pilkington <b>Optiwhite™</b>	Clear	✓	✓	✓	✓	✓	✓	
Pilkington <b>Arctic Blue™</b>	Blue	✓	✓	✓				
Pilkington Decorative Glass Screen Printed		✓	✓	✓	✓	✓	✓	Maximum screened area 2000 x 3600mm (See enclosed data sheet for further details)
Pilkington <b>Activ™</b> Clear and Pilkington <b>Activ™</b> Blue	Clear Blue	✓ ✓	✓ ✓	✓ ✓				

For Pilkington Texture Glass availability, please contact Pilkington Architectural.

#### Notes

Pilkington Planar™ Laminated Safety Glasses are available with a selection of interlayers including PVB and SentryGlas®

Silicone perimeter seals must be compatible with Pilkington Laminated Safety Glass.

A wide range of glass combinations and a choice of clear, translucent and coloured interlayers are available with laminated glasses. Please refer to Pilkington Architectural for advice.

In line with regulations applicable in many European countries, Pilkington recommend the use of laminated glass in overhead or sloping overhead glazing.

### 902 Fitting to Single Pilkington Planar™ Laminated Safety Glass

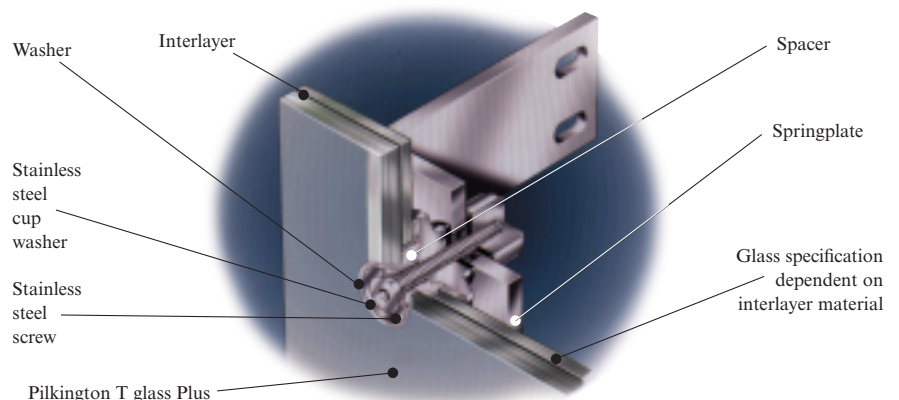

## Specification – Single Pilkington **Planar**™ Laminated Safety Glass

### Indicative Glass combinations

10mm + 6mm or 4mm  
12mm + 6mm or 8mm or 10mm  
15mm + 6mm or 8mm or 10mm

### Pilkington **Planar**™ Laminated Safety Glass

Interlayer: 1.52mm or 2.28mm  
There may be a step up on each side to 3mm

### Glass size – rectangles

Maximum (4mm): 2000 x 3000mm 0 + 4mm  
Maximum (6-19mm): 2000 x 3600mm 0 + 4mm  
(Larger sizes upon request)  
Minimum: 300 x 500mm 0 + 4mm  
Aspect ratio: 14:1 Maximum

Larger glass sizes and weights greater than 350kg subject to enquiry.

### Shape capability

Rectangles and simple shapes. All tolerances will vary depending on the complexity of shape.

### Glass Edge condition

Smooth ground edges giving a flat profile with small ground arris. Shells or chips at edges will be ground out prior to toughening and do not constitute reason for rejection. Corners may be dubbed.  
Some variation in edgework may be discernible on exposed edges where different machines and/or hand forming is a requirement for manufacture. Such variations shall be kept to a minimum.

### Hole drilling – rectangles

Diameter: 38mm ±1mm  
Diameter: 19mm ±1mm Countersunk  
Position: Normally 60mm from glass edge at corners and sometimes along edge. Other configurations subject to confirmation.  
Tolerance: ±2mm from one datum point  
Number: Up to 8

### Method of production

SentryGlas® or PVB.

### Toughening Stress

10/12/15/19mm glass: Pilkington T glass Plus  
(Toughened and Heat Soaked)  
4/6/8mm glass: Heat Strengthened or Pilkington T glass Plus  
as required by design

### Bow

Maximum bow: 0.15% (Float glass)  
0.2% (Ceramic coated glass)

### Roller wave

Mean roller wave depth: 0.05mm  
Maximum edge dip: 0.25mm

Roller wave is usually parallel to the short side and in coated glass should be glazed horizontal where possible.

### Glass marking

Glass will be marked with the Pilkington toughening stamp and will show compliance with regulatory requirements. The mark will be on each glass pane, usually near a corner.

Multiple panes will not necessarily be marked in the same corner.

### Visual quality

#### PVB

Advances in PVB technology in recent years have led to improved edge stability. Under natural exposure conditions the edge of a PVB laminate will be of an acceptable quality when properly installed and maintained. However the possibility of minor delamination cannot entirely be excluded. When viewed from a distance of 3m in transmission and in the vertical position, bubbles, dirt or fibres within the laminate will be considered to be unacceptable if readily visible due to their size or quantity.

#### SentryGlas®

The interlayer technology delivers increased load bearing characteristics and improved overall durability. Laminates with exposed edges shall not develop defects at edges (including holes) as characterised by the Edge Stability Number (ESN), greater than a value of 200, with no defect extending greater than 3mm normal to the chamfered edge of the laminate. Laminates will conform to the specification for process blemishes set forth in ASTM C1172-03, Table 1. When viewed from a distance of 3m in transmission and in the vertical position, bubbles, dirt or fibres within the laminate will be considered to be unacceptable if readily visible due to their size or quantity.

#### Distortion

When laminating toughened or heat strengthened glasses together slight visible distortion in transmission due to the small lens effects will be noted with increase in viewing angle. The phenomenon is not normally a problem in roof glazing, but may be discernible in vertical glazing. On occasion such effects can be increased by the specification of a coated glass. Site inspection should be from a distance of 3m and viewed at right angles to the glass.

#### Installation

Whilst the Pilkington **Planar**™ system is completely weatherproof, the components are not designed to be left in contact with water for extended periods, and adequate ventilation or drainage should be provided to allow the system to dry out periodically. Weatherseals used around the periphery must be compatible with the Pilkington **Planar**™ system and approval from Pilkington should be sought prior to application.

This publication gives a general description of the product and materials. It is the responsibility of the users of this document to ensure that the proposed application of the product is appropriate and that such application complies with all relevant local and national legislation, standards, codes of practice and other requirements. To the extent allowed by law, Pilkington United Kingdom Limited, hereby disclaims all liability howsoever arising from any error in or omission from this publication and all consequences of relying on it. For more information about Pilkington **Planar**™ please visit [www.pilkington.co.uk/planar](http://www.pilkington.co.uk/planar)



**PILKINGTON**  
NSG Group Flat Glass Business

### Building Products - UK

Prescot Road St Helens WA10 3TT United Kingdom  
Telephone 01744 692000 Fax 01744 451326  
[pilkington@respond.uk.com](mailto:pilkington@respond.uk.com)  
[www.pilkington.co.uk](http://www.pilkington.co.uk)